

# ZUNDAPP

ERSATZTEIL-KATALOG  
CATALOGUE OF SPARE PARTS  
CATALOGUE DE PIÈCES DE RECHANGE

**GS 125**  
**Typ/Type 520-05 L5**  
**Sweden**





**ZUNDAPP**  
**Sweden**

# ZUNDAPP



## ERSATZTEIL-KATALOG CATALOGUE OF SPARE PARTS

### GS 125

Typ / Type 520-05L5, Motor / engine 285-20L0, Farbe: racing-rot, Index-Nr. 60  
Colour: racing-red, index No. 60

Inhaltsverzeichnis	Table of Contents	Seite/Page
<u>Motor</u>	<u>Engine</u>	
Gehäuse links	Casing left	4
Gehäuse rechts	Casing right	5
Gehäusedeckel links, Kickstarter	Casing cover left, kickstarter	6
Zylinder, Kurbelwelle	Cylinder, crankshaft	7
Gehäusedeckel rechts, Kupplung	Casing cover right, clutch	8-9
Vergaser, Ansaugstutzen	Carburettor, suction socket	10-11
Getriebe, Kettenritzel	Gearbox, chain pinion	12-13
Fußschaltung	Gear change shaft	14
HKZ-Anlage	CDI-system	15
Auspuffanlage	Exhaust system	16
<u>Fahrgestell</u>	<u>Frame</u>	
Rahmen, Geräuschdämpfer, Fußrasten	Frame, damper, foot rests	17
Teleskopgabel, Lenkungslagersatz	Telescopic fork, steering set	18-19
Hinterradschwinge, Kettenschutz, Federbein	Rear fork, chain guard, spring unit	20
Motoraufhängung, Fußbremse, Radständer	Engine mounting, foot brake, centre prop	21-22
Vorderrad	Front wheel	23-24
Hinterrad, Kette	Rear wheel, chain	25-26
Elektirsche Ausrüstung	Electrical equipment	27-29
Lenker, Armaturen, Seilzüge	Handlebar, armatures, cables	30-31
Schutzbleche, Bügel	Fairings, strap	32
Tank, Sitzbank, Rückblickspiegel, Werkzeugsats	Fuel tank, bench seat, mirror, Tool kit	33
Ausbesserungslack, Fahrzeug-Bild	Tin repair varnish, illustration of motorcycle	34
Schaltplan GS 125	Wiring Diagramm GS 125	35

Gehäuse links  
Casing left



Bild Ill.	Bestel-Nr. Order No.	Benennung	Description	Stck. Pcs.
1-5	285-01.921	Gehäuse links	Casing left	1
2	285-01.203	Lagerbüchse Ø 20	Bearing bush Ø 20	1
3	285-01.223	Nadelhülse 12x20x13 mm	Needle sleeve 12x20x13 mm	1
4	285-01.224	Scheibe 12,3x19,9x1 mm	Washer 12,3x19,9x1 mm	1
5	281-01.135	Öleinfüllschraube	Oil filler screw	1
6	285-01.901	Gehäusedichtung *	Housing gasket *	1
7	285-01.204	Wellendichtring 20x28x6	Shaft seal 20x28x6	1
8	DIN 625/515	Kugellager 6204 C3 20x47x14	Ball bearing 6204 C3 20x47x14	1
9	DIN 84/500	Zylinderschraube BM 6x45	Cylinder bolt BM 6x45	2
10	285-01.192	Gummiring Ø 123	Rubber ring Ø 123	1
11	285-01.194	Wellendichtring 20x30x7	Shaft seal 20x30x7	1
12	285-01.210	Scheibe 42x51,9x0,05 mm	Washer 42x51,9x0,05 mm	var.
12	285-01.211	Scheibe 42x51,9x0,1 mm	Washer 42x51,9x0,1 mm	var.
12	285-01.212	Scheibe 42x51,9x0,2 mm	Washer 42x51,9x0,2 mm	var.
13	285-01.197	Gewindestift M 8x154 mm	Threaded M 8x154 mm	2
14	M181z138	Paßbüchse	Press-fit bush	2
15	285-05.208	Zapfenschraube SW 17	Screw SW 17	1
16	DIN 7603/410	Dichtring A10x14	Sealing ring A10x14	1
17	285-01.183	Wellendichtring 20x30x7	Shaft seal 20x30x7	1

\* Bei Bestellmenge 1 Stück,  
werden 5 Stück abgepackt  
geliefert.

\* When ordering 1 piece, a  
packet of 5 will be delivered

Gehäuse rechts  
Casing right

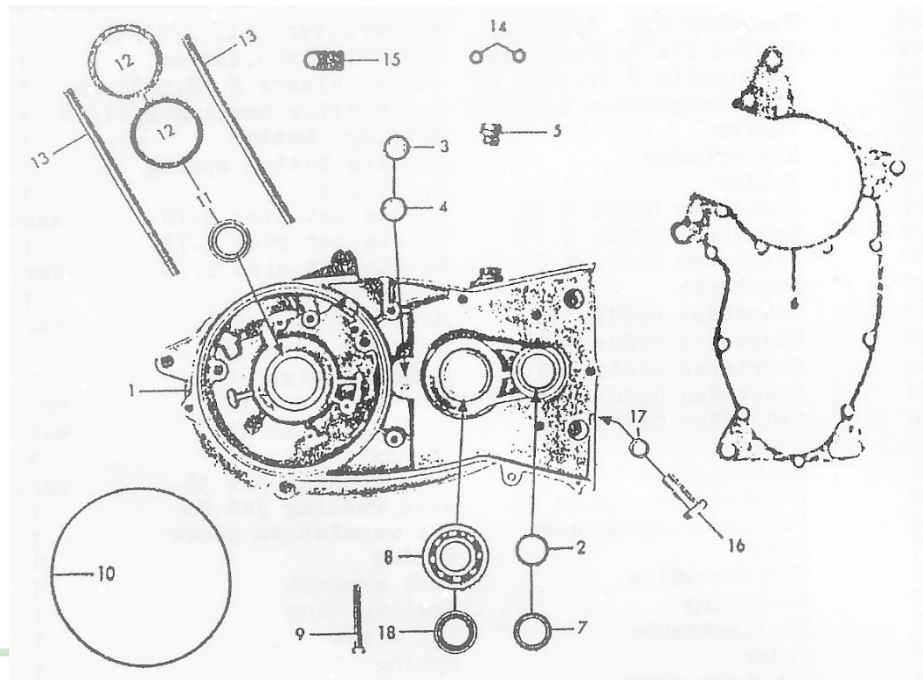

Bild Ill.	Bestel-Nr. Order No.	Benennung	Description	Stck. Pcs.
1-4	285-01.919	Gehäuse rechts - ohne Zylinderrollen - ohne Distanzringe	Casing right - without rollers - without distance rings	1
2	285-01.164	Bundbolzen	Stud	1
3	267-01.128	Lagerbüchse Ø 16	Bearing bush Ø 16	1
4	285-01.923	Lagersatz - bestehend aus: 1 Lagerbüchse Ø 21,5 19 Zylinderrollen 3,5x6,5 1 Distanzring Ø 18 1 Distanzring Ø 19	Bearing set - consisting of: 1 Bearing bush Ø 21,5 19 Rollers 3,5x6,5 1 Distance ring Ø 18 1 Distance ring Ø 19	1
5	285-01.902	Gehäusedichtung *	Housing gasket *	1
6	DIN 1481/800	Spannhülse	Clamping sleeve	1
7	DIN 625/695	Kugellager 16005 C3 25x47x8	Ball bearing 16005 C3 25x47x8	1
8	DIN 625/672	Kugellager 6303 C3 17x47x14	Ball bearing 6303 C3 17x47x14	1
9	DIN 933/670	Ölablaßschraube	Oli drain plugg	1
10	DIN 7603/410	Dichtring A10x14	Sealing ring A10x14	1
11	285-01.210	Scheibe 42x51,9x0,05 mm	Washer 42x51,9x0,05 mm	var.
11	285-01.211	Scheibe 42x51,9x0,1 mm	Washer 42x51,9x0,1 mm	var.
11	285-01.212	Scheibe 42x51,9x0,2 mm	Washer 42x51,9x0,2 mm	var.
12	285-01.220	Wellendichtring 20x30x8/1	Shaft seal 20x30x8/1	1
13	285-01.197	Gewindestift M 8x154 mm	Threaded M 8x154 mm	1
14	DIN 84/540	Zylinderschraube BM 6x65x20	Cylinder bolt BM 6x65x20	1
15	285-01.180	Zylinderschraube M6x154	Cylinder bolt BM M6x154	8
16	285-01.181	Zylinderschraube M6x110	Cylinder bolt BM M6x140	3
17	M181z138	Paßbüchse	Press-fit bush	2
18	247-01.126	Typschild	Model plate	1
--	DIN 1476/200	Halbrundkerbnagel	Round-head	3

\* Bei Bestellmenge 1 Stück,  
werden 5 Stück abgepackt  
geliefert.

\* When ordering 1 piece, a  
packet of 5 will be delivered

Gehäusedeckel links, Kickstarter-  
Einrichtung Casing cover left,  
kickstarter

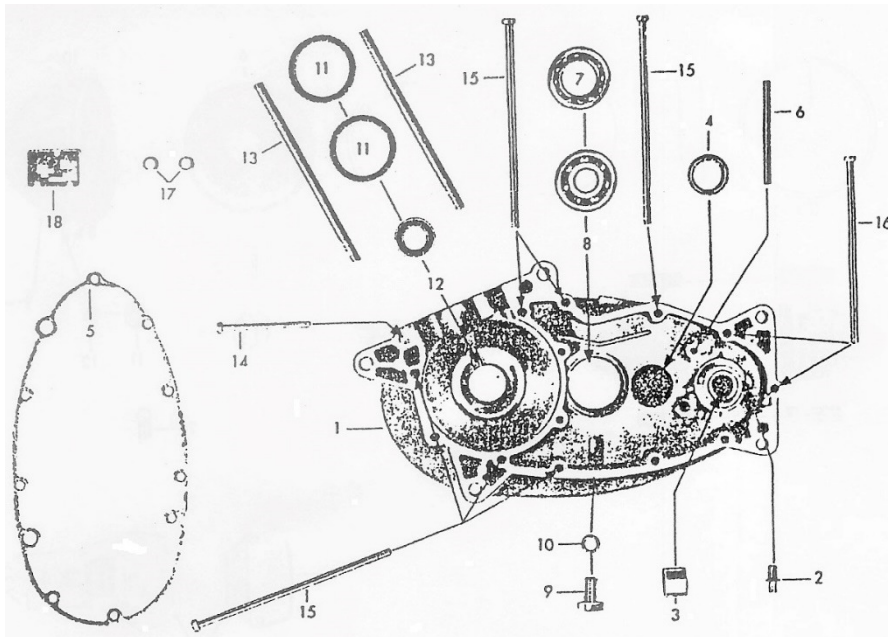

Bild Ill.	Bestel-Nr. Order No.	Benennung	Description	Stck. Pcs.
1	285-01.177	Gehäusedeckel links	Casing cover left	1
2	DIN 84/450	Zylinderschraube BM 6x22	Cylinder bolt BM 6x22	1
3	DIN 84/520	Zylinderschraube BM 6x55	Cylinder bolt BM 6x55	2
4	285-05.235	Kickstarterwelle allein	Kickstarter spindle single	1
5	265-05.255	Scheibe 22,1x32x0,2 mm	Washer 22,1x32x0,2 mm	var.
5	265-05.257	Scheibe 22,1x32x0,3 mm	Washer 22,1x32x0,3 mm	var.
6	DIN 471/530	Sicherungsring 20x1,2	Retaining ring 20x1,2	1
7	267-05.910	Mitnehmer	Dog	1
8	267-05.334	Bremsfeder	Brake spring	1
9	285-05.169	Starterrad	Starter gear	1
10	267-05.312	Scheibe 20,2x28x1,0 mm	Washer 20,2x28x1,0 mm	2
10	267-05.310	Scheibe 20,2x28x0,1 mm	Washer 20,2x28x0,1 mm	var.
10	267-05.313	Scheibe 20,2x28x0,5 mm	Washer 20,2x28x0,5 mm	var.
10	267-05.315	Scheibe 20,2x28x0,2 mm	Washer 20,2x28x0,2 mm	var.
11	285-05.209	Starteranschlag	Starter buffer	1
12	DIN 5401/350	Kugel Ø 5	Ball Ø 5	2
13	DIN 471/435	Sicherungsring 20x1,75	Retaining ring 20x1,75	1
14	285-05.207	Drehfeder	Spring	1
15	265-05.245	Scheibe 16,2x28x1,0 mm	Washer 16,2x28x1,0 mm	1
16	285-05.665	Kickstarterhebel kpl.	Kickstarter lever cpl.	1
17	285-05.324	Kickstarterhebel allein	Kickstarter lever single	1
18	285-05.303	Kickstartermuffe allein	Kickstarter sleeve single	1
19	DIN 7/450	Zylinderstift 8x6x36	Cylinder pin 8x6x36	1
20	DIN 5401/550	Kugel Ø 8	Ball Ø 8	1
21	267-05.319	Drucksfeder	Compression spring	1
22	285-05.299	Feder	Spring	1
23	285-05.302	O-Ring Ø 12x2	O-ring Ø 12x2	1
24	285-05.300	Scheibe 12,1x16,5x1,0	Washer 12,1x16,5x1,0	1
25	DIN 472/220	Sicherungsring 22x1	Retaining ring 22x1	1
26	285-05.178	Sicherungsblech	Retaining sheet	1
27	DIN 7603/205	Dichtring A6,5x9,5	Sealing ring A6,5x9,5	1
28	285-05.211	Schraube SW 11	Screw SW 11	1



Zylinder, Kurbelwelle  
Cylinder, crankshaft

Bild Ill.	Bestel-Nr. Order No.	Benennung	Description	Stck. Pcs.
1	285-02.736	Zylinder mit Kolben	Cylinder with piston	1
2	285-02.729	Ein-Ring-Kolben $\varnothing$ 54 *	One-ring-piston $\varnothing$ 54 *	1
3	285-02.176	L-Kolbenring $\varnothing$ 52x2	L-Piston $\varnothing$ 52x2	1
4	DIN 73123/650	Sicherungsring 15x1,2	Retaining ring 15x1,2	2
5	285-02.637	Flansch	Flange	1
6	DIN 912/450	Zylinderschraube M8x25	Cylinderbolt M8x25	2
7	DIN 433/500	Scheibe 8,4	Washer 8,4	2
8	285-02.162	Dichtring	Gasket	1
9	285-02.152	Zylinderfußdichtung	Cylinder gasket	1
10	285-02.153	Zylinderkopfdichtung	Cylinder head gasket	1
11	285-04.108	Ansaugdichtung	Gasket for suction socket	1
12	285-02.173	Zylinderkopf	Cylinder head	1
13	DIN 1440/550	Scheibe $\varnothing$ 8	Washer $\varnothing$ 8	4
14	DIN 934/500	Sechskantmutter M8	Hexagon nut M8	4
15	DIN 931/475	Sechskantschraube M7x45	Hexagon bolt M7x45	2
16	DIN 125/500	Scheibe A 7,4	Washer A 7,4	2
17	285-03.907	Kurbelwelle	Crankshaft	1
18	285-03.139	Nadelkäfig 15x19x20 mm	Needle cage 15x19x20 mm	1
19	285-03.120	Kolbenbolzen	Piston pin	1
20	285-03.905	Kugellager 20x52x15 mm	Ball bearing 20x52x15 mm	2

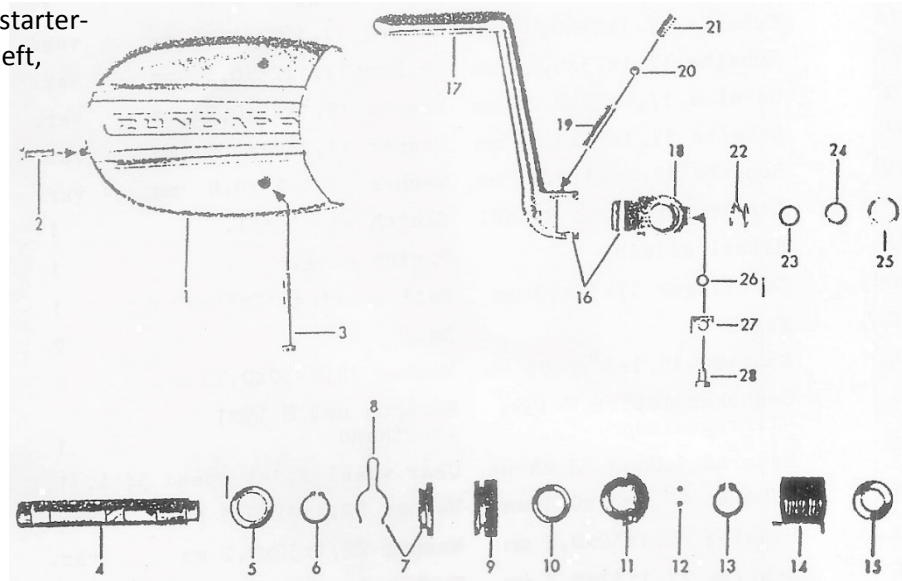
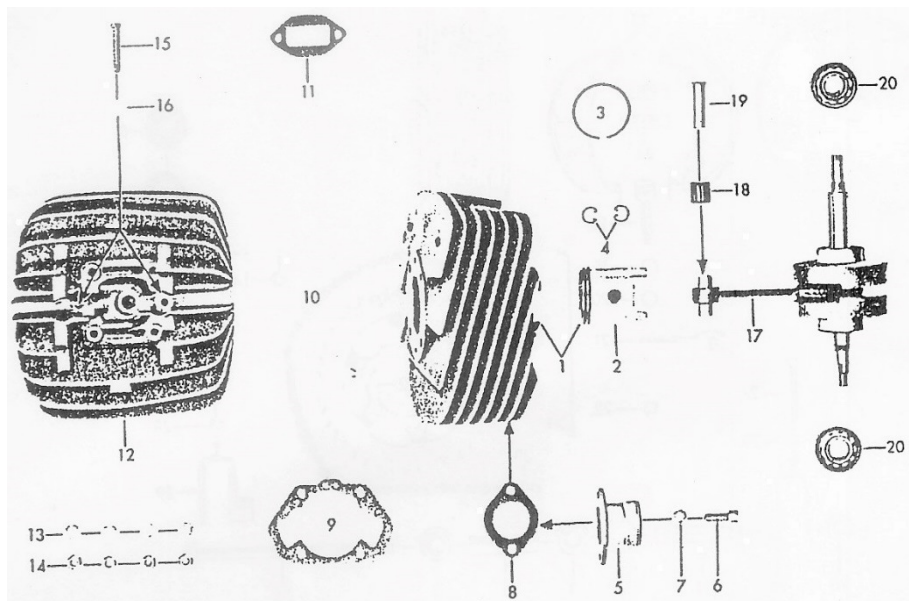
\* Verschieden Toleranzen  
Unbedingt den am Kolben-  
boden eingeschlagenen  
Kennbuchstaben angeben.

\* Different tolerances  
Indicate tolerance letter being  
stamped on the cylinder head.

Gehäusedeckel rechts, Kupplung  
Casing cover right, clutch  
1/2



Bild Ill.	Bestel-Nr. Order No.	Benennung	Description	Stck. Pcs.
1	285-01.922	Gehäusedeckel links	Casing cover left	1
2	DIN 625/395	Kugellager 6201 C3 11x32x10	Bal bearing 6201 C3 11x32x10	1
3	265-06.602	Kupplungshebel	Clutch lever	1
4	281-06.114	Scheibe 0,2 mm dick	Washer 0,2 mm thick	1
4	281-06.115	Scheibe 0,5 mm dick	Washer 0,5 mm thick	var.
5	265-06.112	Drehfeder	Spring	1
6	405-15.388	Dichtring	Sealing ring	1
7	DIN 6799/500	Sicherungsscheibe 8	Retaining washer 8	1
8	285-05.325	Führungsbolzen mit Nut	Bolt with groove	1
-	DIN 471/200	Sicherungsring 8x0,8	Retaining ring 8x0,8	1
9	265-06.104	Kupplungszunge	Clutch tongue	1
10	265-06.106	Einstellschraube	Set screw	1
11	DIN 7603/410	Dichtring A 10x14	Sealing ring A 10x14	1
12	DIN 936/560	Sechskantmutter MF10x1	Hexagon nut MF10x1	1
13	265-05.109	Haltefeder	Retaining spring	2
14	DIN 84/250	Zylinderschraube AM 4x6	Cylinder bolt AM 4x6	2
15	DIN 1481/260	Spannhülse 3x12	Dowel 3x12	1
16	DIN 7603/205	Dichtring A 6x10	Sealing ring A 6x10	1
17	DIN 85/265	Linsenschraube AM 6x12	Oval-head screw AM 6x12	1
18	285-01.105	Anschlußkappe	Connector cap	1
19	DIN 964/440	Linsensenkschraube AM 5x20	Oval-head screw AM 5x20	2
20	285-06.101	Ritzel	Pinion	1



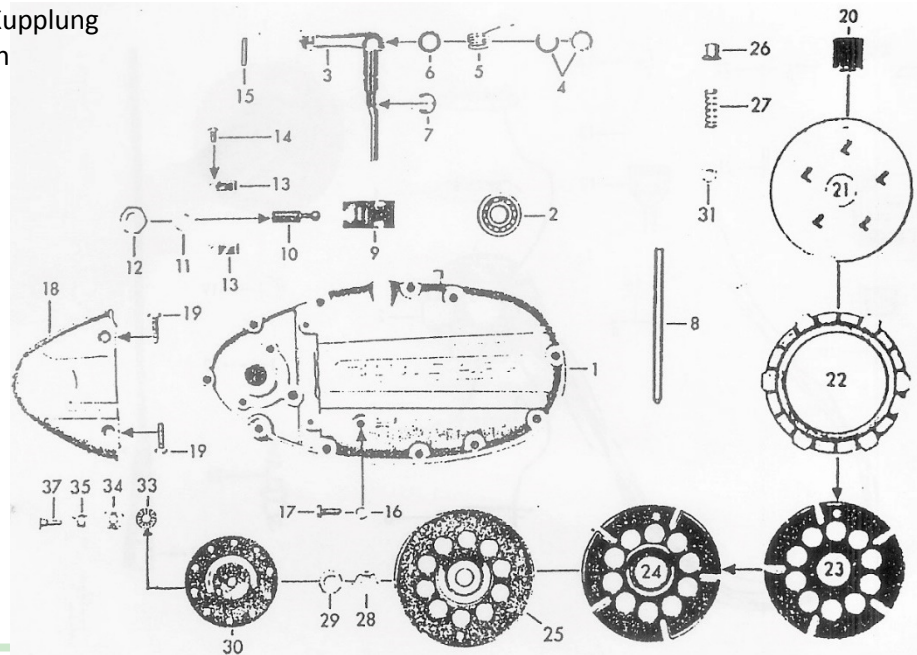
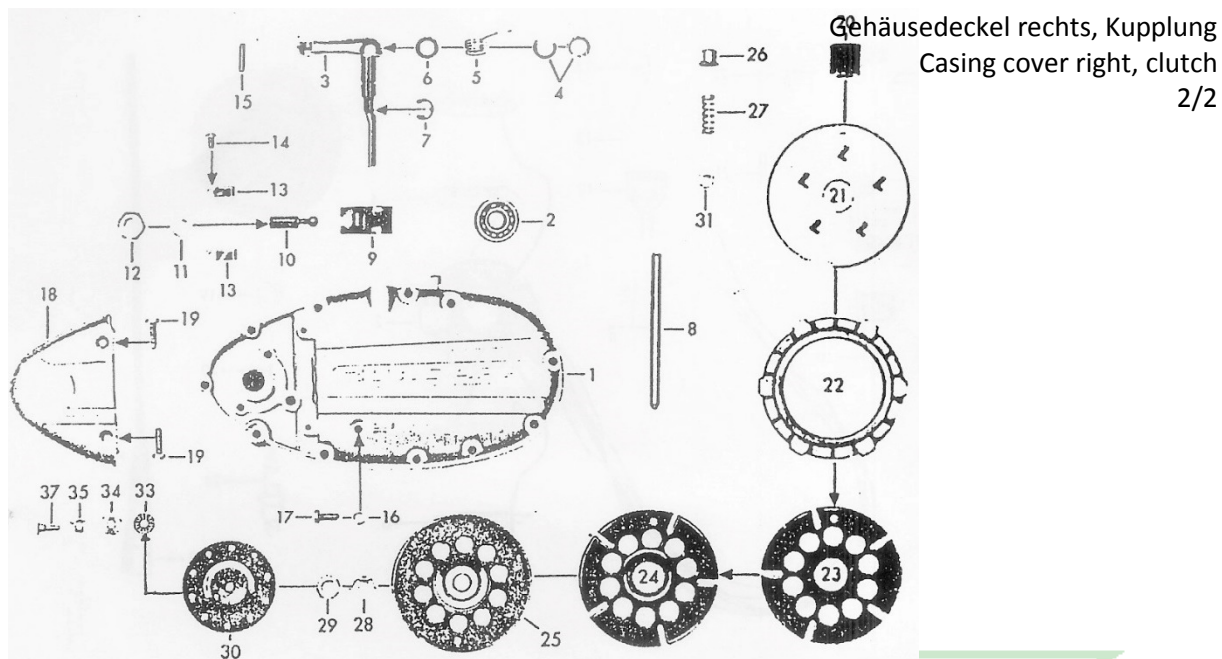

Gehäusedeckel rechts, Kupplung  
Casing cover right, clutch  
2/2

Bild Ill.	Bestel-Nr. Order No.	Benennung	Description	Stck. Pcs.
21	285-06.603	Haltescheibe	Retaining plate	1
22	281-06.166	Lamelle	Disk	6
23	265-06.130	Kupplungsscheibe	Clutch plate	4
24	265-06.131	Kupplungsscheibe	Clutch plate	1
25	265-06.127	Deckscheibe	Cover plate	1
26	261-06.155	Federhülse	Spring sleeve	10
27	285-06.107	Kupplungsfeder	Clutch spring	10
28	284-06.104	Sicherungsblech	Retaining sheet	1
29	265-06.202	Sechskantmutter	Hexagon nut	1
30	285-06.108	Druckscheibe	Thrust plate	1
31	DIN 934/	Sechskantmutter	Hexagon nut	5
32	285-06.115	Nadellager 10x24 mm	Needle bearing 10x24 mm	1
33	285-06.116	Scheibe 10x24x1 mm	Washer 10x24x1 mm	1
34	285-06.111	Scheibe 10,1x18x0,1 mm	Washer 10,1x18x0,1 mm	1
34	285-06.112	Scheibe 10,1x18x0,2 mm	Washer 10,1x18x0,2 mm	var.
34	285-06.113	Scheibe 10,1x18x0,4 mm	Washer 10,1x18x0,4 mm	var.
34	285-06.114	Scheibe 10,1x18x0,8 mm	Washer 10,1x18x0,8 mm	var.
35	285-06.605	Druckstift	Thrust pin	1

Vergaser, Ansaugstutzen  
Carburettor, suction  
socket 1/2



Bild Ill.	Bestel-Nr. Order No.	Benennung	Description	Stck. Pcs.
1	285-04.726	Vergaser kpl. 2/27/10	Carburettor cpl. 2/27/10	1
-	285-04.202	Büchse 27x35x20,4x1 mm	Bush 27x35x20,4x1 mm	1
-	285-04.204	Gummimuffe Ø 37,5x34 mm	Rubber sleeve Ø 37,5x34 mm	1
2	285-04.959	Vergasergehäuse 2/27/10	Carburettor housing 2/27/10	1
3	285-04.908	Tupfer	Priming button	1
4	276-04.920	Tupferfeder	Priming button spring	1
5	276-04.916	Splint	Split pin	1
10	285-04.937	Nadeldüse Größe 2.70	Needle jet size 2.70	var.
10	285-04.936	Nadeldüse Größe 2.73	Needle jet size 2.73	1
10	285-04.938	Nadeldüse Größe 2.76	Needle jet size 2.76	var.
11	285-04.912	Mischrohr	Choke tube	1
12	285-04.961	Hauptdüse Größe 118	Main jet size 118	var.
12	285-04.950	Hauptdüse Größe 120	Main jet size 120	var.
12	285-04.964	Hauptdüse Größe 123	Main jet size 123	1
12	285-04.951	Hauptdüse Größe 125	Main jet size 125	var.
12	285-04.960	Hauptdüse Größe 130	Main jet size 130	var.
13	285-04.913	Scheibe	Washer	1
14	285-04.901	Leerlaufdüse Größe 35	Idle running jet 35	var.
14	285-04.902	Leerlaufdüse Größe 40	Idle running jet 40	1
15	220-04.904	Luftregulierschraube	Air regulation screw	1
16	285-04.915	Feder	Spring	1
17	267-04.940	Schlauchtülle	Hose grommet	1
18	267-04.946	Dichtring	Sealing ring	1
19	285-04.916	Stellschraube	Set screw	1
20	285-04.917	Feder	Spring	1
21	285-04.957	Schwimmergehäuse mit Überlaufrohr	Float housing with tube	1

Vergaser, Ansaugstutzen  
Carburettor, suction socket  
2/2

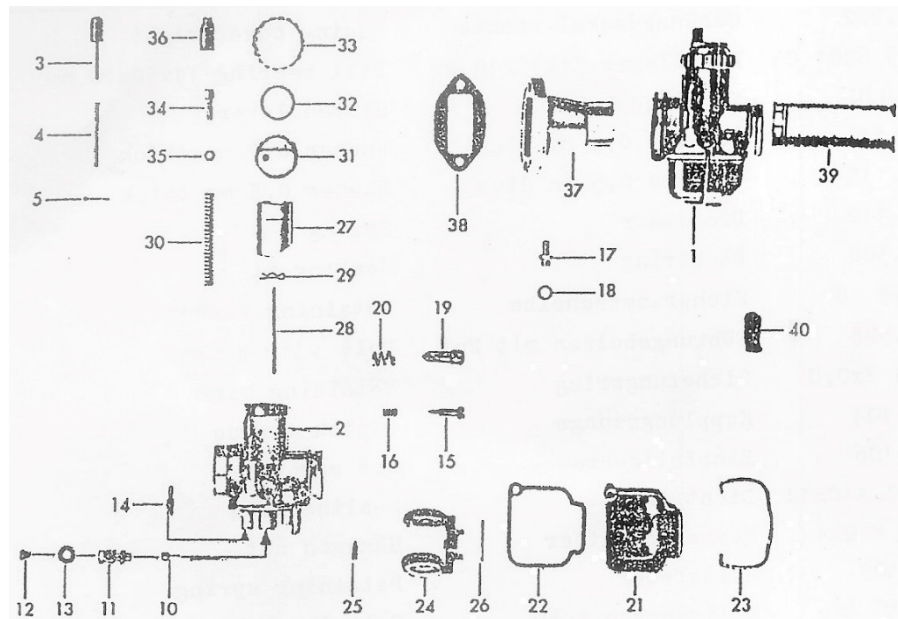

Bild Ill.	Bestel-Nr. Order No.	Benennung	Description	Stck. Pcs.
22	285-04.919	Dichtring	Gasket	1
23	285-04.920	Federbügel	Spring clip	1
24	285-04.921	Schwimmer	Float	1
25	285-04.922	Schwimmernadel	Float needle	1
26	285-04.923	Stift	Pin	1
27	285-04.958	Gasschieber	Gas slide	1
28	285-04.947	Düsennadel	Jet needle	1
29	285-04.952	Klemmbügel	Clampig strap	1
30	285-04.953	Schieberfeder	Slide spring	1
31	285-04.973	Deckelplatte	Cover plate	1
32	285-04.931	Gummidichtring	Rubber sealing ring	1
33	285-04.954	Deckelverschraubung	Cover screwing	1
34	267-04.938	Seil- Verstellerschraube	Adjuster screw	1
35	251-04.927	Gegenmutter	Lock nut	1
36	517-17.111	Gummitülle	Rubber sleeve	2
37	285-04.974	Ansaugstutzen	Suction socket	1
		-mit gummimuffe	-with rubber sleeve	1
38	285-04.108	Ansaugdichtung	Gasket for suction socket	1
-	DIN 433/400	Scheibe 6,4	Washer 6,4	2
-	DIN 934/400	Sechskantmutter M6	Hexagon nut M6	2
39	285-04.185	Rohr	Tube	1
40	285-04.941	Luftschieber	Gas slide	1
-	285-04.967	Siebkörper	Filter body	1
-		-im Schwimmergehäuse	-for float housing	1
-	520-10.703	Schlauchschelle S 46/9	Clamping clip S 46/9	1
-	285-04.734	Schlauchschelle S 50/9	Clamping clip S 50/9	1
		Einige Abbildungen sind mit den Teile nicht identisch	Some illustrations are not identical with the parts	

Getriebe, Kettenritzel  
Gearbox, chain pinion  
1/2



Bild Ill.	Bestel-Nr. Order No.	Benennung	Description	Stck. Pcs.
1	285-05.637	Getriebewelle	Drift shaft	1
2	265-05.178	Scheibe 17,1x23x0,05 mm	Washer 17,1x23x0,05 mm	var.
2	265-05.177	Scheibe 17,1x23x0,1 mm	Washer 17,1x23x0,1 mm	var.
2	265-05.176	Scheibe 17,1x23x0,2 mm	Washer 17,1x23x0,2 mm	var.
2	265-05.175	Scheibe 17,1x23x0,5 mm	Washer 17,1x23x0,5 mm	var.
2	265-05.179	Scheibe 17,1x23x0,8 mm	Washer 17,1x23x0,8 mm	var.
4	285-05.903	Kupplungsrad mit Ritzel	Clutch wheel cpl.	1
5	286-05.102	Ritzel allein	Pinion single	1
6	DIN 625/250	Kugellager 6003 C3 17x35x10	Ball bearing 6003 C3 17x35x10	1
7	DIN 5401/350	Kugel Ø 5	Ball Ø 5	2
8	276-05.198	Scheibe 15,2x30x0,75	Washer 15,2x30x0,75	2
9	285-05.151	Sechskantmutter M 15x1 - linksgewinde	Hexagon nut M 15x1 - lefthand	1
10	285-05.243	Zahnrad 1. Gang, 34 Zähne	Gear wheel f. 1 st. speed 34 t.	1
11	265-05.256	Scheibe 22,1x32x0,1	Washer 22,1x32x0,1	var.
11	265-05.255	Scheibe 22,1x32x0,2	Washer 22,1x32x0,2	var.
11	265-05.257	Scheibe 22,1x32x0,3	Washer 22,1x32x0,3	var.
12	285-05.242	Zahnrad 2. Gang, 26 Zähne	Gear wheel f. 2 st. speed 26 t.	1
13	285-05.241	Zahnrad 3. Gang, 23 Zähne	Gear wheel f. 3 st. speed 23 t.	1
14	285-05.239	Zahnrad 4. Gang, 24 Zähne	Gear wheel f. 4 st. speed 24 t.	1
15	285-05.237	Zahnrad 5. Gang, 19 Zähne	Gear wheel f. 5 st. speed 19 t.	1

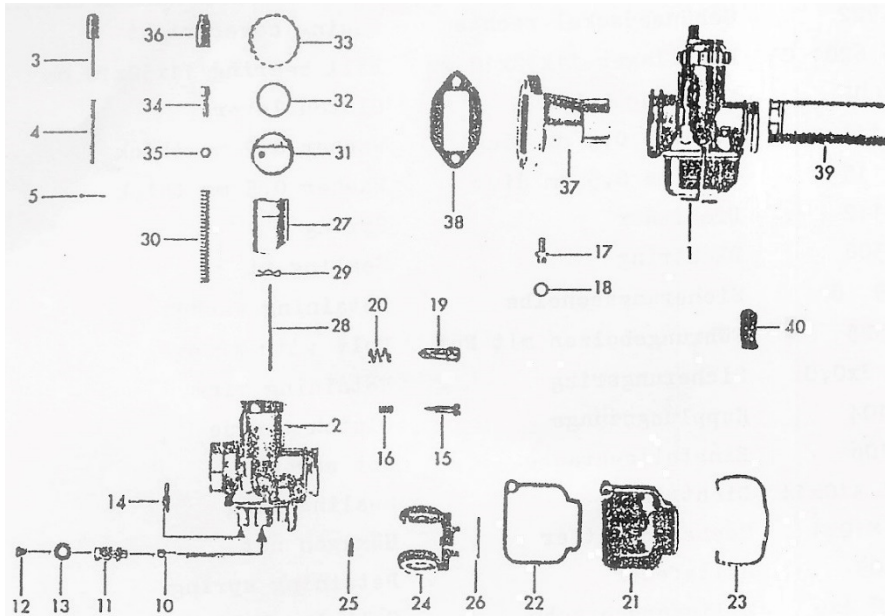

16	276-05.119	Sechskantmutter M 15x1 - rechtsgewinde	Hexicon nut M 15x1 - righthand	1
17	285-05.286	Kettenritzel 12 Zähne	Chain pinion 12 teeth	var.
17	285-05.199	Kettenritzel 13 Zähne	Chain pinion 13 teeth	1
17	285-05.200	Kettenritzel 14 Zähne	Chain pinion 14 teeth	var.
17	285-05.201	Kettenritzel 15 Zähne	Chain pinion 15 teeth	var.
18	267-05.310	Scheibe 20,2x28x0,1	Washer 20,2x28x0,1	var.
18	267-05.315	Scheibe 20,2x28x0,2	Washer 20,2x28x0,2	var.
18	267-05.312	Scheibe 20,2x28x1,0	Washer 20,2x28x1,0	1
19	285-05.609	Schaltwelle	Selector shaft	1
20	278-05.101	Kugel Ø 7	Ball Ø 7	20
21	281-05.152	* Distanzring Ø 18	* Distance ring Ø 18	1
22	281-05.153	* Distanzring Ø 19	* Distance ring Ø 19	1
23	285-05.334	* Zylinderrolle - DIN 5402 3,5x6,5	* Roller - DIN 5402 3,5x6,5	19
24	283-05.673	Ziehkeil * siehe auch Lagersatz Seite 5, Bild-Nr. 4	Pull cotter * See also bearing set page 5, ill. No. 4	1

Fußschaltung  
Gear change shaft

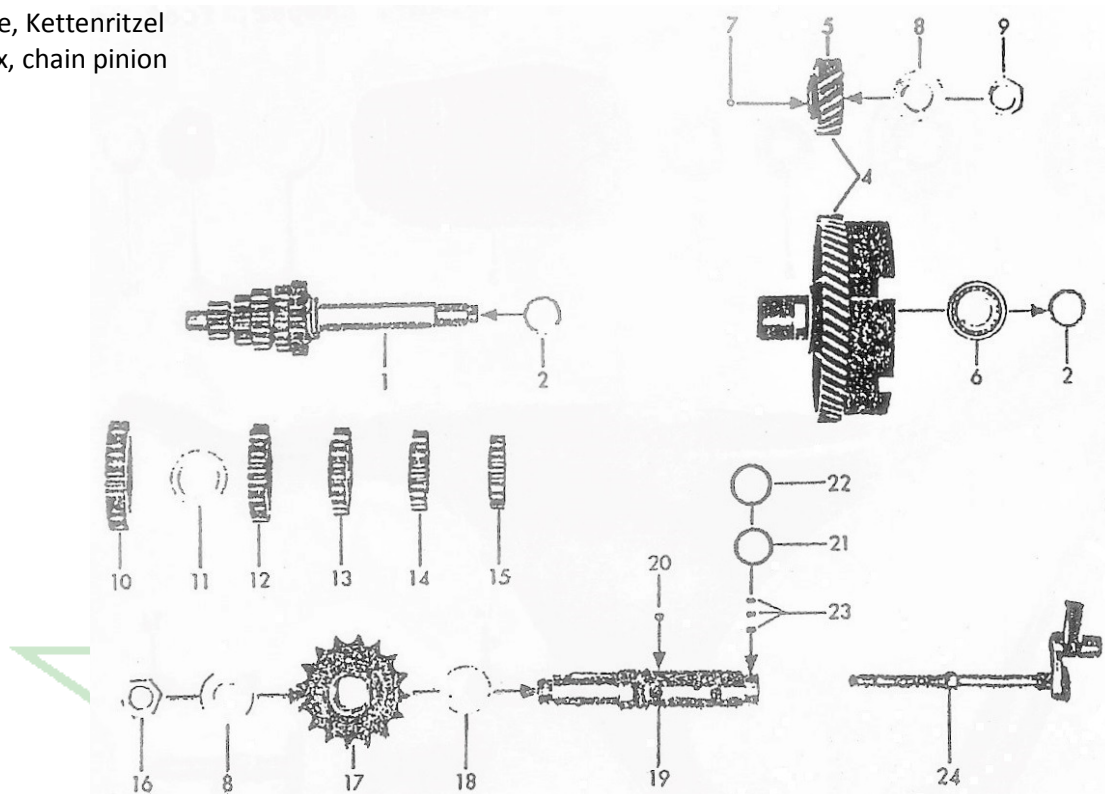
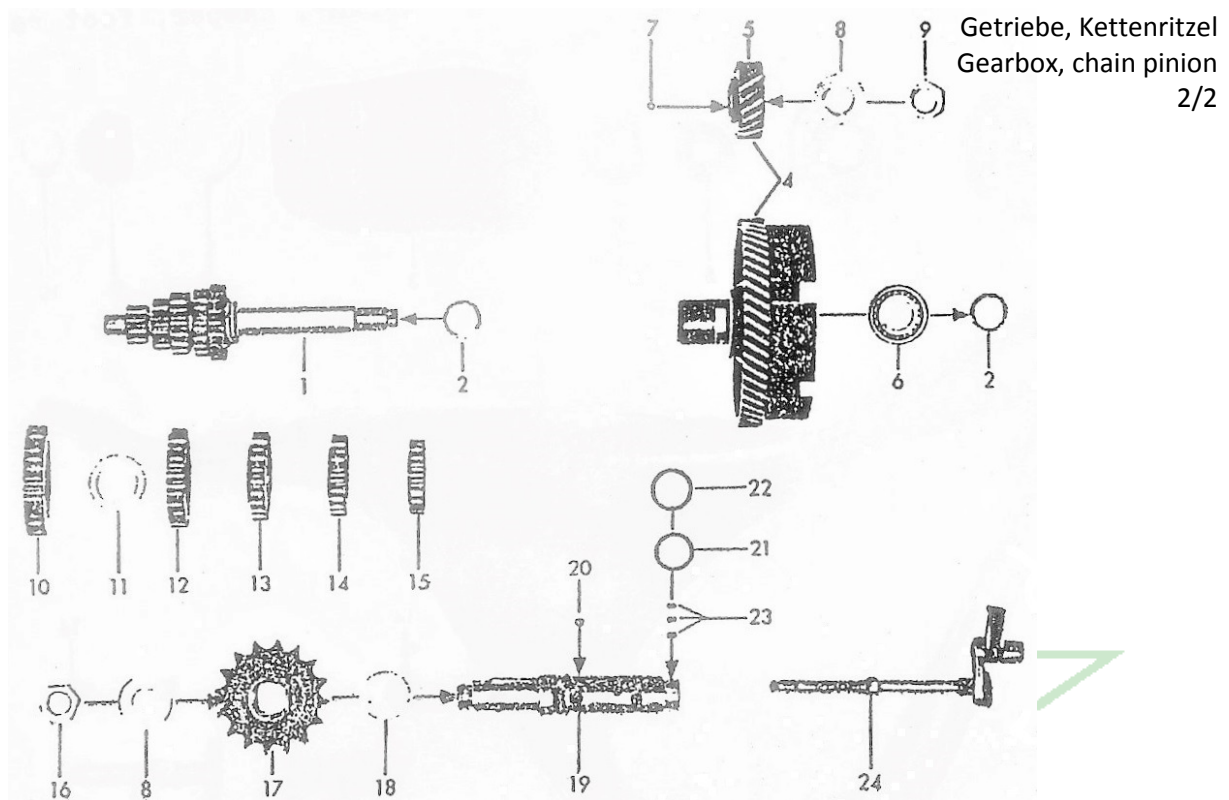

Bild Ill.	Bestel-Nr. Order No.	Benennung	Description	Stck. Pcs.
1	285-05.723	Fußschaltwelle kpl.	Gear change shaft cpl.	1
2	285-05.667	Fußschaltwelle allein	Gear change shaft single	1
3	267-05.125	Arretierbolzen	Bolt	1
4	267-05.126	Druckfeder	Compression spring	1
5	285-05.307	Schaltklinke	Latch	2
6	267-05.585	Klinkenfeder	Spring	1
7	285-05.310	Klinkenabweiser	Pawl guide rail	1
-	DIN 660/345	Halbrundniet 2,6x5	Rivet 2,6x5	1
8	278-05.100	Rückholfeder	Return spring	1
9	267-05.244	Scheibe 16,2x22,8x0,1	Washer 16,2x22,8x0,1	var.
10	DIN 471/350	Sicherungsring 16x1	Retaining ring 16x1	1
11	283-05.716	Fußschalthebel	Foot schift lever	1
12	616z25S	Gummimuffe	Rubber sleeve	1
13	DIN 933/346	Sechskantschraube M 6x16	Hexagon bolt M 6x16	1
14	267-05.112	Einstellglocke	Setting bell	1
15	285-05.322	O-Ring Ø 30 mm	O-ring Ø 30 mm	1
16	267-05.113	Unterlegplättchen	Shim	2
17	DIN 920/430	Linsenschraube M6x15	Oval-head screw	2
18	267-05.130	Gummikappe	Rubber cap	1



Bild Ill.	Bestel-Nr. Order No.	Benennung	Description	Stck. Pcs.
-	285-07.729	HKZ-Anlage kpl. 58 Watt	CDI-system cpl. 58 Watt	1
1	285-07.906	Polrad allein	Flywheel single	1
2	285-07.907	Ankerplatte kpl.	Armature plate cpl.	1
3	284-07.904	Ladegeneratoranker	Charging generator armature	1
4	285-07.903	Lichtspule 35 W	Lighting coil 35 W	1
5	285-07.905	Schlußlichtspule 5 W	Rear light coil 5 W	1
6	285-07.904	Ladespule 18 W	Charging coil 18 W	1
7	284-07.907	Elektronikbox	Electronic box	1
8	265-07.914	Schutzkappe	Protecting cap	1
9	285-07.143	Steckhülsegehäuse	Plug housing	1
10	304-07.249	Steckhülse	Plug sleeve	4
11	285-07.139	Schutzkappe	Protecting cap	1
12	304-16.242	Verschlusskappe	Cap	1
13	304-16.216	Flachsteckergehäuse	Flat plug contact housing	1
14	304-16.204	Flachstecker	Flat plug contact	5
15	285-07.140	Halter	Mounting bracket	1
16	285-07.129	Halteplatte	Retaining plate	1
17	285-07.105	Kabeltülle	Cable grommet	1
18	283-07.100	Kabeltülle	Cable grommet	1
19	285-07.135	Bundmutter M12x1-SW17-	Nut with collar M12x1-SW17-	1
20	DIN 6888/300	Schebenfeder 3x3,7	Plate spring 3x3,7	2
--	DIN 84/293	Zylinderschraube AM 4x16	Cylinder bolt AM 4x16	2
21	520-16.256	Rundsteckerhülse	Round plugg sleeve	2
22	DIN 84/450	Zylinderschraube AM 6x22	Cylinder bolt AM 6x22	2
--	DIN 125/400	Scheibe A 6,4	Washer A 6,4	2
--	DIN 934/400	Sechskantmutter M6	Hexagon nut M6	1
23	285-07.732	Entstörstecker	Interference-suppressor plug	1
24	285-07.114	Zündkerze W 280 M 1	Spark plug W 280 M 1	1

Auspuffanlage  
Exhaust system

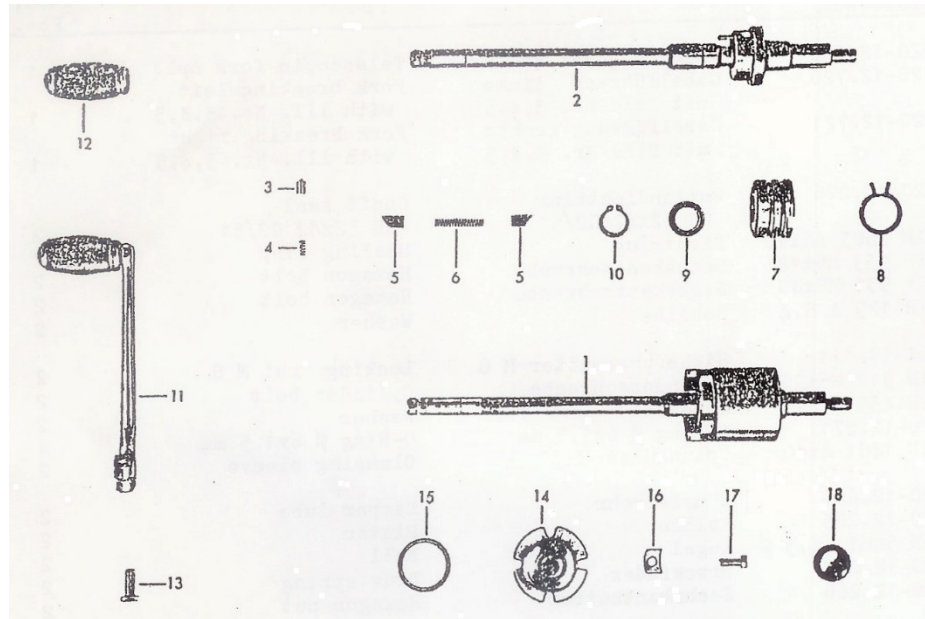

Bild Ill.	Bestel-Nr. Order No.	Benennung	Description	Stck. Pcs.
1	520-22.714	Auspuff kpl.	Exhaust silencer cpl.	1
2	520-22.906	Dämpferrohr	Damper tube single	1
3	520-22.907	Steinwolle-Pressling	Pressed rticle	1
4	DIN 933/300	Sechskantschraube M6x10	Hexagon bolt M6x10	1
-	520-22.908	Sicherungsblech	Retaining sheet	1
5	517-15.127	Zugfeder	Draw spring	2
6	DIN 934/500	Sechskantmutter M8	Hexagon nut M8	3
7	DIN 127/560	Federring B 8	Spring washer B 8	6
8	520-10.288	Schwingmetallpuffer	Swing suspension buffer	3
9	DIN 9021/700	Scheibe A 8,4	Washer A 8,4	3
10	DIN 933/540	Sechskantschraube M8x12	Hexagon bolt M8x12	3
11	520-22.139	Auspuffhalter	Exhaust holder	1
12	DIN 934/400	Sechskantmutter M6	Hexagon nut M6	1
13	DIN 127/400	Federring B 6	Spring washer B 6	1
14	DIN 125/400	Scheibe A 6,4	Washer A 6,4	1
15	DIN 933/346	Sechskantschraube M6x16	Hexagon bolt M6x16	1
--	520-22.114	Asbestschnur Ø 1,5 und 264 mm lang	Asbestos cord Ø 1,5 und 264 mm long	1

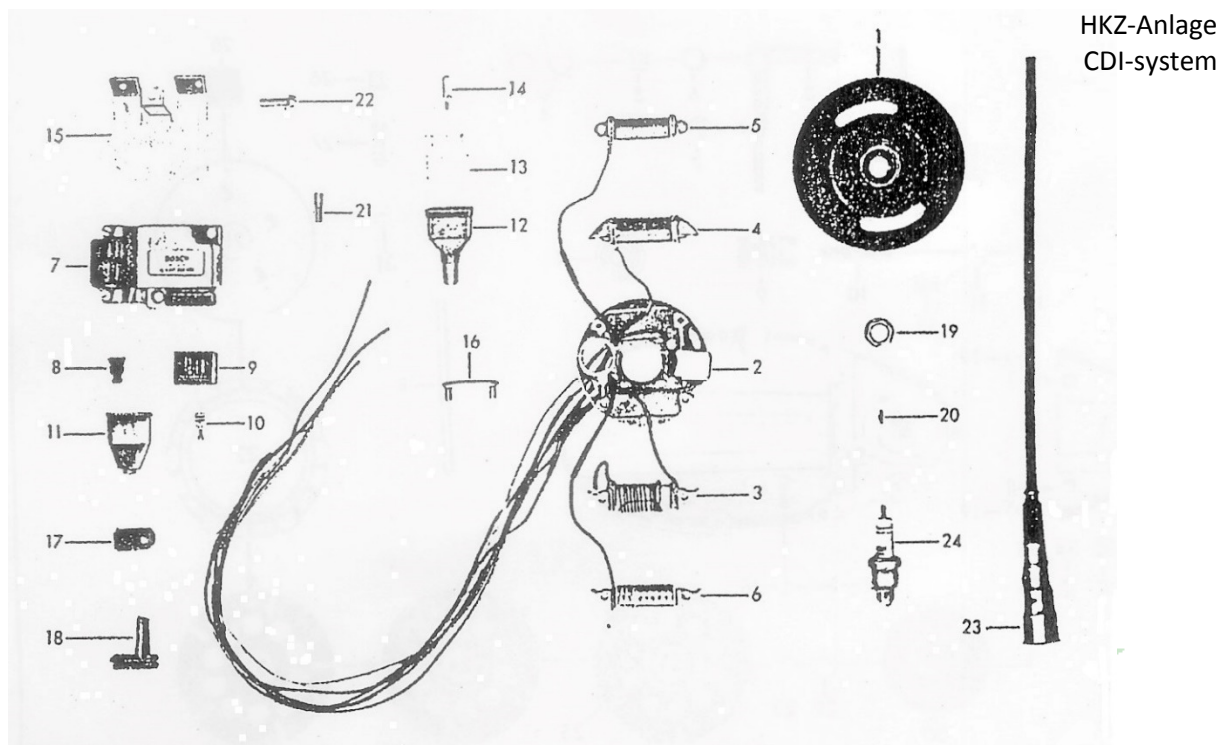

Rahmen, Ansauggeräuschdämpfer, Fußrasten  
Frame, damper, foot rests

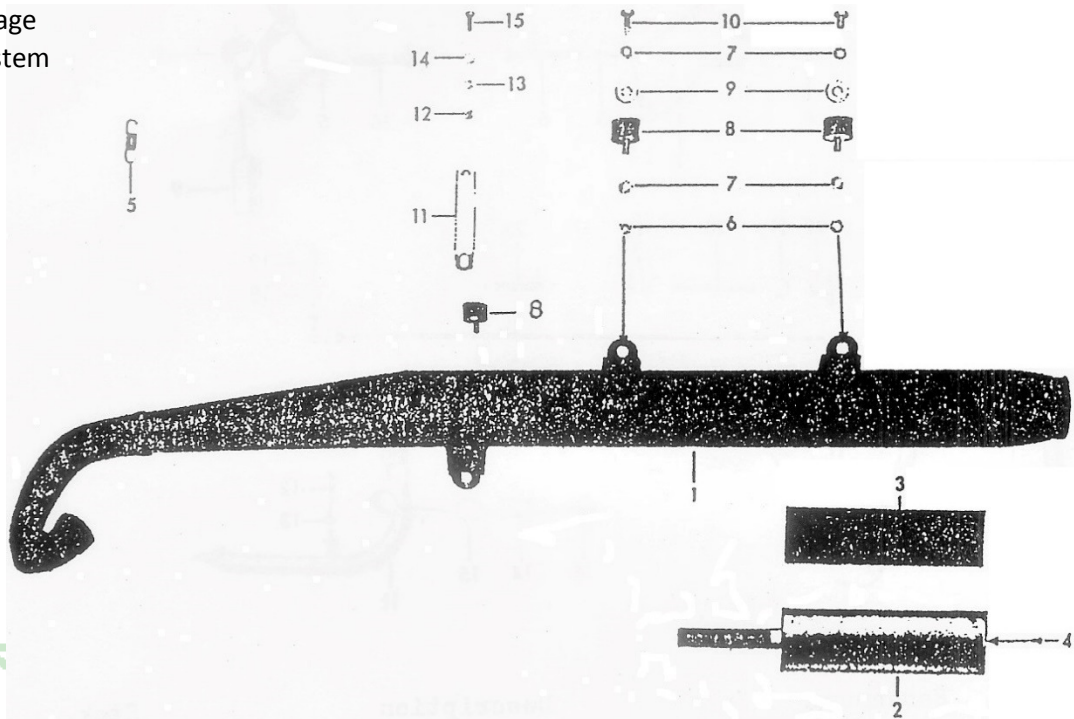

Bild Ill.	Bestel-Nr. Order No.	Benennung	Description	Stck. Pcs.
1	520-10.675	* Rahmen ohne verkleidung	* Frame without cover	1
-	520-10.361	Büchse (Kunststoff)	Bush (plastic)	2
2	517-10.710	Sicherheitsschloß	Lock set	1
3	520-10.717	Geräuschdämpfer kpl.	Noise damper cpl.	1
4	520-10.379	Dichtring Ø 59	Sealing ring Ø 59	1
5	520-10.324	Dichtring Ø 34,8	Sealing ring Ø 34,8	1
6	520-10.608	Filtereinsatz	Filter insert	1
7	520-10.901	Filterdeckel kpl.	Filter cover cpl.	1
-	DIN 7971/500	Zylinderblechschraube BZ 4,2x6,5	Cylinder bolt BZ 4,2x6,5	1
8	520-10.318	Schlauchselle Ø 76	Hose clip Ø 76	1
9	520-10.317	Faltenbalg	Bellow	1
10	520-10.703	Schlauchselle Ø 46	Hose clip Ø 46	1
11	520-10.674	Rahmenverkleidung GS 125	Cover for GS 125	1
--	520-10.253	Druckknopf	Snap fastener	4
--	DIN 84/250	Zylinderschraube AM 4x6	Cylinder bolt AM 4x6	4
12	520-14.731	Fußraste links	Foot rest left	1
13	520-14.732	Fußraste rechts	Foot rest right	1
14	520-14.241	Gummimuffe	Rubber sleeve	2
15	DIN 931/550	Sechskantschraube M8x42/22	Hexagon bolt M8x42/22	2
--	561-17.111	Sicherungsmutter M8	Locking nut M8	2
--	DIN 127/560	Federring B 10	Spring washer B 10	4
--	DIN 934/610	Sechskantmutter M8	Hexagon nut M8	4
--	435-10.900	Typschild	Model plate	1
--		Fahrgestell-Nr. angeben	Indicate frame No.	
--	DIN 1476/250	Kerbnagel 2x5	Pin 2x5	2
		* unbedingt farbe angeben	* state colour	

Teleskopgabel, Lenkungslagersatz

Telescopic fork, steering set

1/2

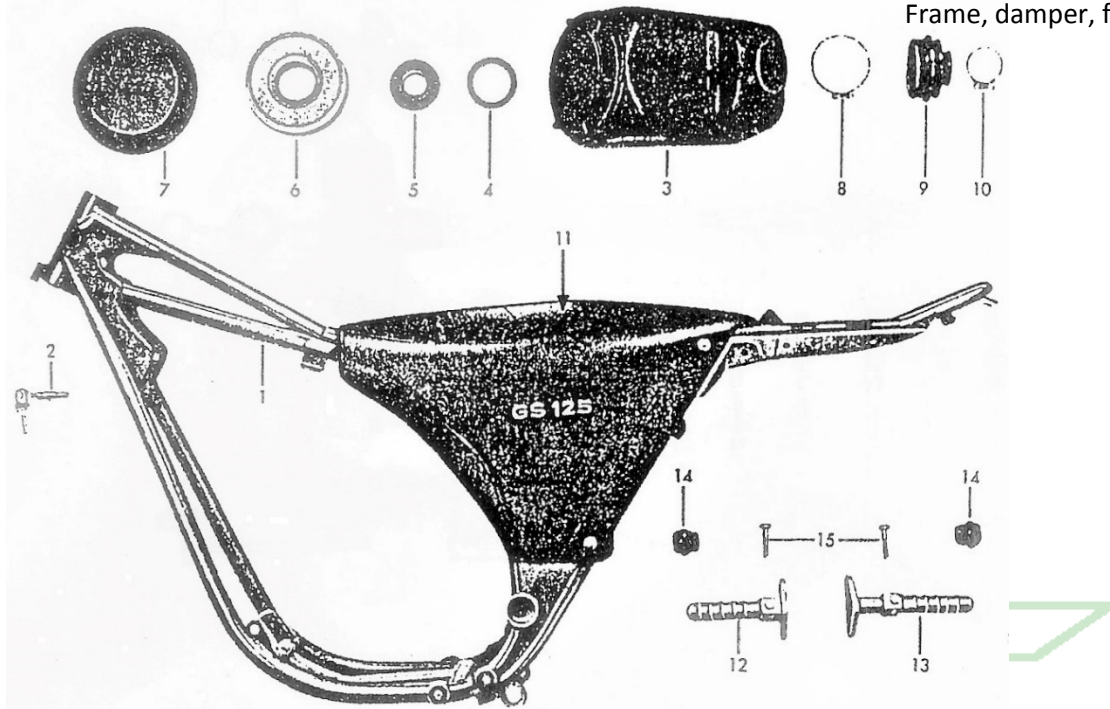

Bild Ill.	Bestel-Nr. Order No.	Benennung	Description	Stck. Pcs.
-	520-12.900	Teleskopgabel kpl.	Telescopic fork cpl.	1
1	520-12.720	Gabelführung links mit Bild-Nr. 3,4,5	Fork breaking left with ill.-No. 3,4,5	1
2	520-12.721	Gabelführung rechts mit Bild-Nr. 3,4,5	Fork breaking right with ill.-No. 3,4,5	1
3	520-12.226	Wellendichtring QH 32x42 G2/51	Shaft seal QH 32x42 G2/51	2
4	DIN 7603//200	Dichtring	Sealing ring	2
5	DIN 933/320	Sechskantschraube M6x12	Hexagon bolt M6x12	2
6	DIN 931/540	Sechskantschraube M8x40	Hexagon bolt M8x40	2
7	DIN 125/550	Scheibe A 8,4	Washer A 8,4	2
8	561-17.111	Sicherungsmutter M8	Locking nut M8	2
9	DIN 912/310	Zylinderschraube M6x25	Cylinderbolt M6x25	2
10	DIN 433/400	Scheibe 4,3	Washer 4,3	2
11	520-12.271	O-Ring Ø 6x1,5 mm	O-ring Ø 6x1,5 mm	4
12	DIN 1481/400	Spannhülse 4x10	Clamping sleeve 4x10	2
13	520-12.660	Dämpferrohr	Damper tube	2
14	520-12.265	Kolben	Piston	2
15	DIN 5401/320	Kugel Ø 4,5	Ball	2
16	520-12.267	Drückfeder	Draw spring	2
17	520-12.266	Sechskantmutter	Hexagon nut	2
18	520-12.264	Gewindestange	Threaded bar	2
19	520-12.274	Führungsstück	Guide piece	2
20	520-12.198	Verschlussschraube	Locking screw	2



Teleskopgabel, Lenkungsagersatz  
Telescopic fork, steering set  
2/2

Bild Ill.	Bestel-Nr. Order No.	Benennung	Description	Stck. Pcs.
21	DIN 127/400	Federring B 6	Spring washer B 6	2
22	DIN 934/400	Sechskantmutter M6	Hexagon nut M6	2
23	520-12.263	Pfropfen	Plug	2
24	520-12.199	Verschlussschraube	Locking screw	2
25	520-12.273	Druckfeder	Draw spring	2
26	520-12.272	Federträger	Spring support	2
27	520-12.661	Gabelrohr	Fork tube	2
28	520-12.257	Gummiring	Rubber ring	2
30	518-12.100	Faltenbalg	Bellow	2
31	518-12.103	Schlauchschelle Ø 48	Hose clip Ø 48	4
34	520-12.635	Gabelverbindungen unten	Fork connection bottom	1
35	1871 z 156	Gabellaufring	Fork bearing race	2
36	DIN 5401/500	Kugel Ø 6	Ball	36
37	1871 z 155	Rahmenlaufring	Frame bearing race	2
38	520-12.204	Gabelverbindung oben	Fork connection top	1
39	519-12.110	Kegelmutter	Cone nut	1
40	520-12.143	Hutmutter	Locking nut	1
41	DIN 137/380	Federscheibe B 7	Spring washer B 7	4
42	DIN 933/524	Sechskantschraube M7x50	Hexagon bolt M7x50	4
--	520-12.188	Öse f. Gabelverbindung unten	Metall ring for fork connection bottom	1

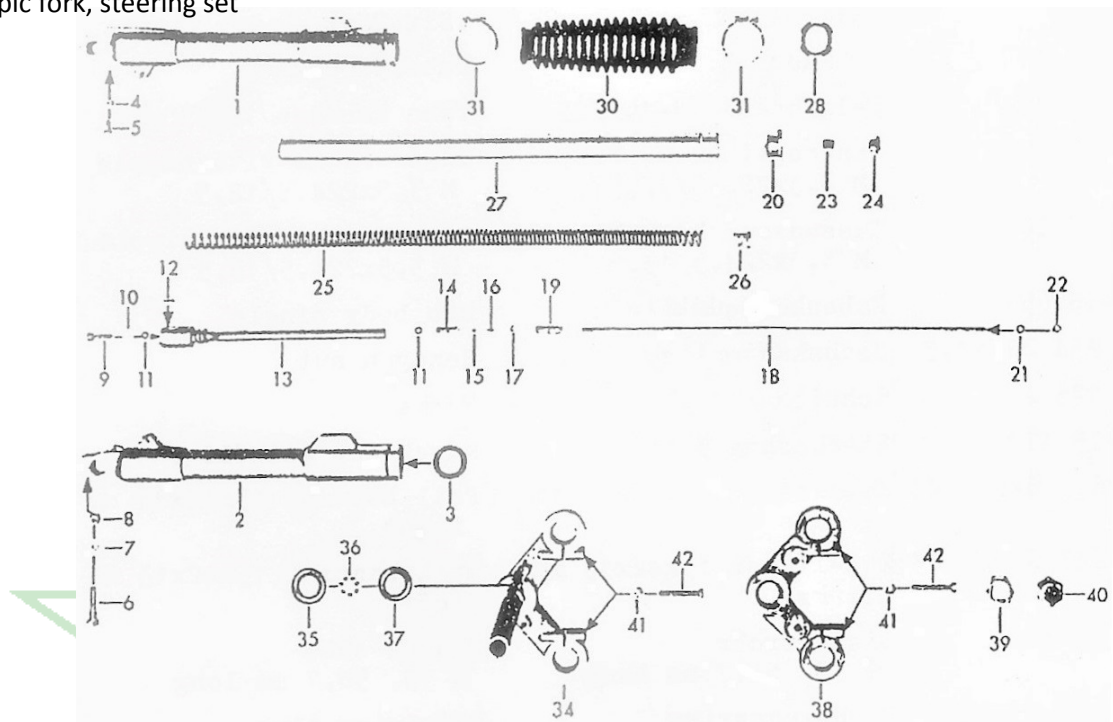
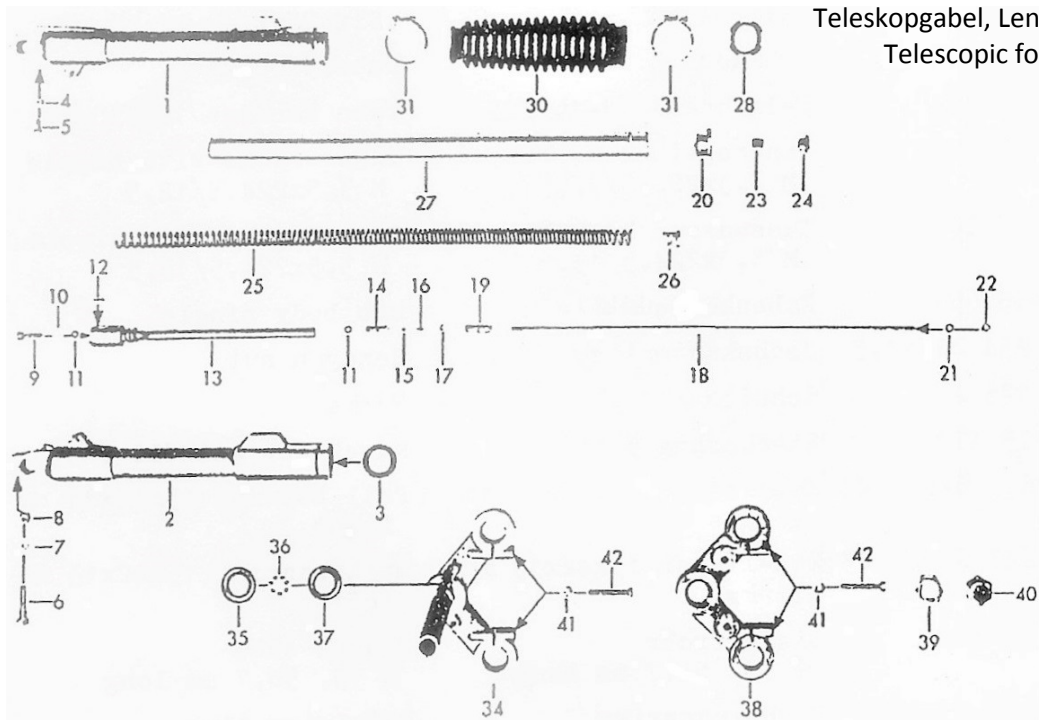
Hinterradschwinge, Kettenschutz, Federbein  
Rear fork, chain guard, spring unit



Bild Ill.	Bestel-Nr. Order No.	Benennung	Description	Stck. Pcs.
1	520-14.739	Hinterradschwinge	Rear fork	1
2	520-14.627	Elastic-Büchse	Elastic bush	2
3	520-14.216	Achse	Axle	1
4	520-14.217	Mutter	Nut	2
5	DIN 127/720	Federring B 16	Spring washer B 16	2
6	520-14.237	Kappe	Cap	2
7	520-14.734	Federbein kpl.	Spring unit cpl.	2
-	520-14.733	Stoßdämpfer allein	Chock absorber single	2
-	520-14.266	Druckfeder allein	Draw spring single	2
8	520-14.616	Kettenschutz	Chain guard	1
9	DIN 125/550	Scheibe A 8,4	Washer A 8,4	4
10	DIN 137/400	Federscheibe B 8	Spring washer B 8	4
11	DIN 931/556	Sechskantschraube M8x35	Hexagon bolt M8x35	4
12	561-17.111	Sicherungsmutter M8	Locking nut M8	5
13	DIN 933/554	Sechskantschraube M8x16	Hexagon bolt M8x16	2
14	520-14.143	Scheibe 8,5x17x1,5 mm	Washer 8,5x17x1,5	4
15	510-18.218	Kettenführung	Chain guide	1
16	520-18.617	Platte	Plate	1
17	DIN 125/400	Scheibe A 6,4	Washer A 6,4	2
18	DIN 127/400	Federring B 6	Spring washer B 6	2
19	DIN 931/312	Sechskantschraube M6x45	Hexagon bolt M6x45	2

Motoraufhängung, Fußbremse, Radständer  
 Engine mounting, foot brake, centre prop  
 1/2

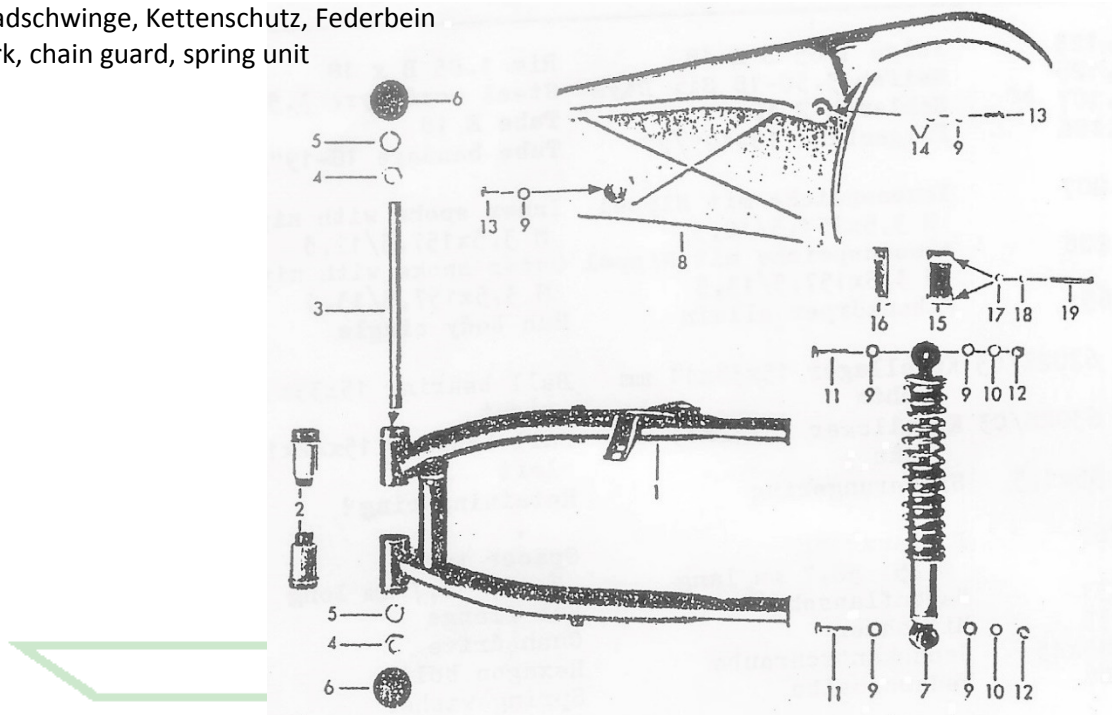

Bild Ill.	Bestel-Nr. Order No.	Benennung	Description	Stck. Pcs.
1	520-18.615	Motorträger vorne	Engine support	1
2	520-18.613	Schwingmetallpuffer	Rubber-metal buffer	2
3	DIN 127/640	Federring B 10	Spring washer B 10	4
4	DIN 934/610	Sechskantmutter M10	Hexagon nut M10	2
5	DIN 127/560	Federring B 8	Spring washer B 8	5
6	DIN 931/630	Sechskantschraube M8x70	Hexagon bolt M8x70	2
7	DIN 933/663	Sechskantschraube M10x12	Hexagon bolt M10x12	2
8+9	520-18.703	Motoraufhängung hinten	Engine mounting rear	1
9	520-14.627	Elastic-Büchse	Elastic bush	1
-	520-18.118	Scheibe 28x38x4,5 mm	Washer 28x38x4,5 mm	1
10	DIN 931/590	Sechskantschraube M8x55	Hexagon bolt M8x55	2
11	520-17.609	Fußbremshebel	Foot brake lever	1
12	DIN 933/365	Sechskantschraube M6x22	Hexagon bolt M6x22	1
13	DIN 934/400	Sechskantmutter M6	Hexagon nut M6	3
14	520-17.179	Lagermuffe	Bearing sleeve	2
15	520-17.141	Ring	Ring	2
16	DIN 931/556	Sechskantschraube M8x35	Hexagon bolt M8x35	1
--	DIN 7346/260	Spannhülse 3x12	Clamping sleeve 3x12	1
17	520-17.636	Bremsstange	Brake linkage	1
18	DIN 125/400	Scheibe A 6,4	Washer A 6,4	1
--	DIN 94/300	Splint 2x12	Split pin 2x12	1
19	519-17.106	Bolzen	Pin	1
20	519-17.110	Feder	Spring	1

Motoraufhängung, Fußbremse, Radständer  
 Engine mounting, foot brake, centre prop  
 2/2

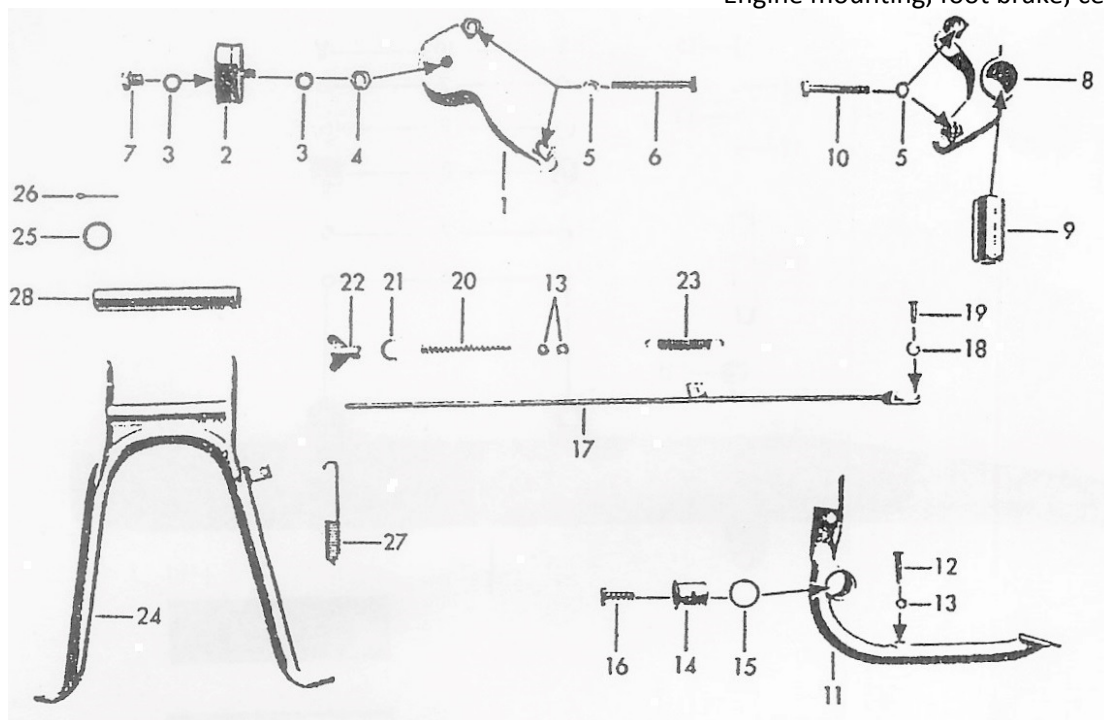

Bild Ill.	Bestel-Nr. Order No.	Benennung	Description	Stck. Pcs.
21	433-17.100	Sicherungsblech	Retaining sheet	1
22	428-17.103	Flügelmutter	Wing nut	1
23	517-17.103	Zugfeder	Pull spring	1
24	520-21.606	Radständer	Prop	1
25	517-21.113	Scheibe 19,3x26,8x0,5 mm	Washer 19,3x26,8x0,5 mm	2
--	517-17.110	Scheibe 18,2x25,7x0,2 mm	Washer 18,2x25,7x0,2 mm	var.
--	520-14.248	Scheibe 18,5x26x1 mm	Washer 18,5x26x1 mm	var.
26	DIN 94/400	Splint 3x30	Split pin 3x30	2
27	517-21.109	Zugfeder	Draw spring	1
28	520-21.106	Lagerrohr	Bearing tube	1

Sweden



Vorderrad  
Front wheel  
2/2

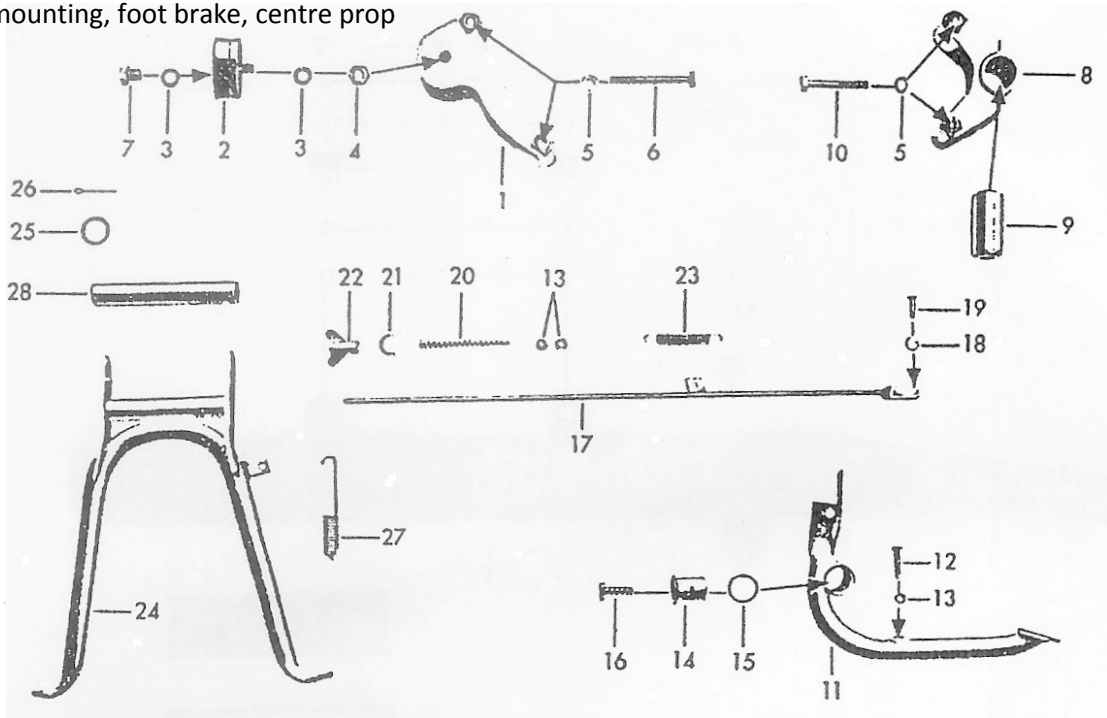

Bild Ill.	Bestel-Nr. Order No.	Benennung	Description	Stck. Pcs.
11	520-15.645	Bremsdeckel allein	Brake plate single	1
12	515-15.100	Gewindestutzen	Threaded socket	1
13	520-15.196	Tachoritzel	Speedometer pinion	1
14	DIN 9045/650	Sprengring A 25	Circlip A 25	1
15	520-15.195	Filzring	Felt ring	1
16	517-21.921	Bremsbacke nur paarweise lieferbar	Brake shoe 1 pair	2
17	517-15.133	Zugfeder	Drawspring	2
18	561-15.620	Bremsschlüssel	Brake spindle	1
19	267-05.597	Scheibe	Washer	1
20	405-15.388	Dichtring	Sealing ring	1
21	517-15.607	Bremshebel	Brake lever	1
22	DIN 127/560	Federring B 8	Spring washer B 8	1
23	DIN 936/410	Sechskantmutter M8x1	Hexagon nut M8x1	1
24	520-15.177	Ankerlasche	Strip	1
25	DIN 127/640	Federring B 10	Spring washer B 10	1
26	DIN 934/610	Sechskantmutter M10	Hexagon nut M10	1
27	DIN 933/380	Sechskantschraube M6x30	Hexagon bolt M6x30	1
28	DIN 125/400	Scheibe A 6,4	Washer A 6,4	1
29	517-22-111	Sicherungsmutter M6	Locking nut M6	1



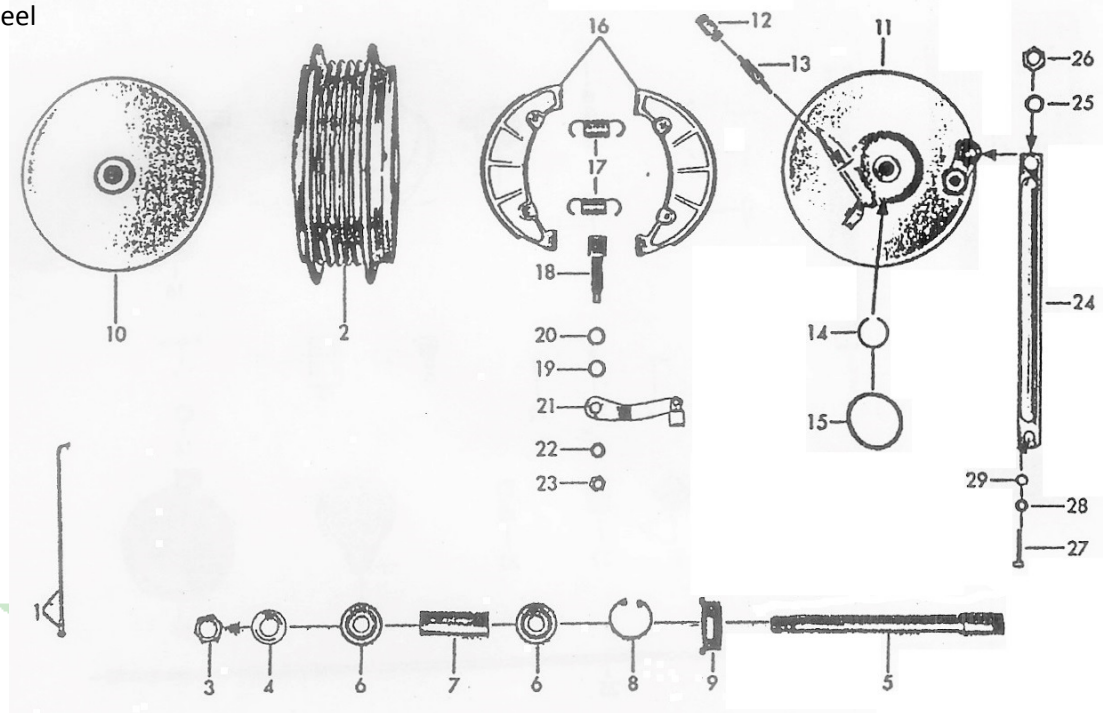

Bild Ill.	Bestel-Nr. Order No.	Benennung	Description	Stck. Pcs.
-	519-15.123	Felge 1.85 B x 18	Rim 1.85 B x 18	1
-	519-15.126	Reifen 3.50-18 Six Days	Steel cord tyre 3.50-18	1
-	521-15.107	Schlauch E 18	Tube E 18	1
-	520-15.186	Felgenband 18-19"/27	Tube bandage 18-19"/27	1
1	520-15.207	Innenspeiche m. Nippel M3,5x157,5/12,5	Inner spoke with nipple M3,5x157,5/12,5	18
1	520-15.208	Aussenspeiche m. Nippel M3,5x157,5/13,5	Outer spoke with nipple M3,5x157,5/13,5	18
2	520-15.651	Nabenkörper allein	Hub body single	1
3	DIN 625/440	Kugellager rechts 6202Z/C3 - 15x35x11 mm	Ball bearing right 6202Z/C3 - 15x35x11 mm	1
3	DIN 625/650	Kugellager links 6302Z/C3 - 15x42x13 mm	Ball bearing left 6302Z/C3 - 15x42x13 mm	1
4	DIN 472/330	Sicherungsring J 35x1,5	Retainingring J 35x1,5	1
5	520-15.262	Distansrohr Ø 15, 58,7 mm lang	Spacer tube Ø 15, 58,7 mm long	1
-	520-15.231	Nabenflansch	Hub flange	1
-	520-15.235	Mitnehmer	Cush drive	1
-	DIN 931/570	Sechskantschraube M8x45	Hexagon bolt M8x45	6
-	DIN 137/400	Federscheibe B8	Spring washer B8	6
8	DIN 625/295	Kugellager 6004 Z 20x42x12 mm	Ball bearing 6004 Z 20x42x12	2
9	520-15.216	Wellendichtring 25x42x6/1 mm	Shaft seal 25x42x6/1 mm	1
11	520-15.209	Haltebüchse	Retaining bush	1
12	520-15.246	Kettenrad 46 Zähne	Chain sprocket 46 teeth	1

Hinterrad, Kette  
Rear wheel, chain  
2/2

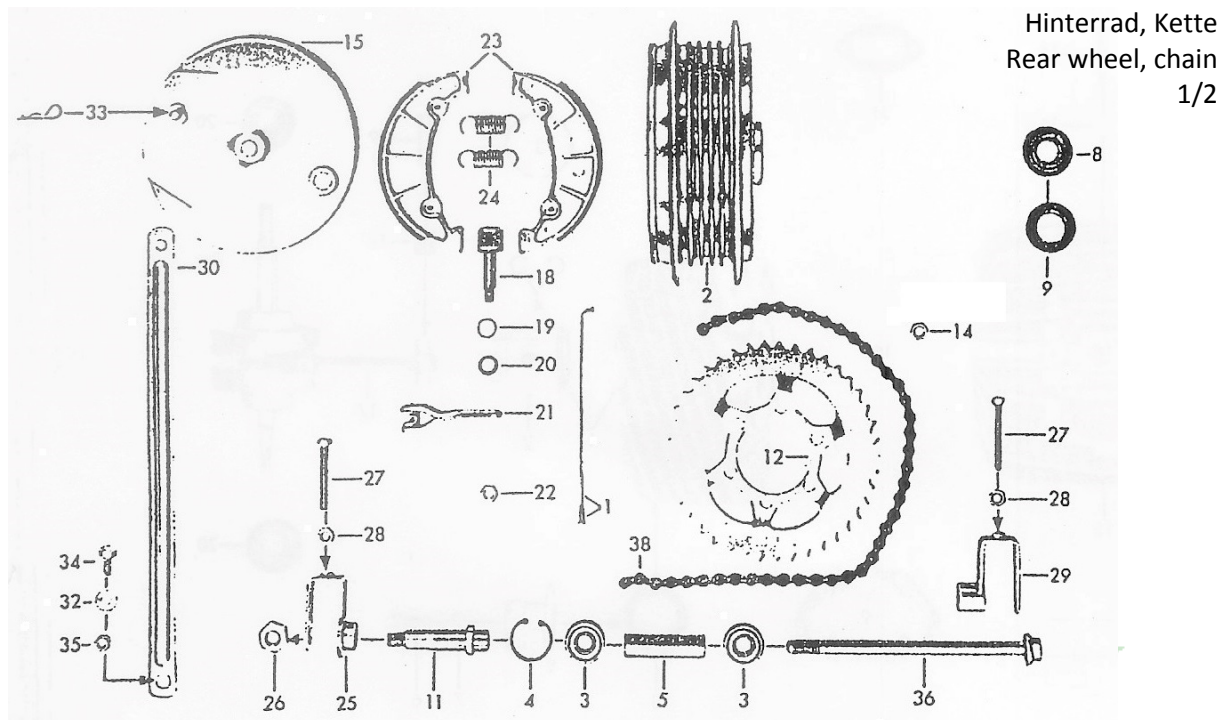

Bild Ill.	Bestel-Nr. Order No.	Benennung	Description	Stck. Pcs.
14	561-17.111	Sicherungsmutter M8	Locking nut M8	6
15	520-15.644	Bremsdeckel allein	Brake plate single	1
18	520-15.608	Bremsschlüssel	Brake spindle	1
19	267-05.597	Scheibe	Washer	1
20	405-15.388	Dichtring	Sealing ring	1
21	520-15.632	Bremshebel	Brake lever	1
22	DIN 936/410	Sechskantmutter M8x1	Hexagon nut M8x1	1
23	517-15.609	Bremsbacke nur paarweise lieferbar	Brake shoe 1 pair	2
24	517-15.133	Zugfeder	Draw spring	2
25	520-15.613	Kettenspanner links	Chain tensioner left	1
26	433-15.131	Mutter	Nut	1
27	DIN 933/524	Sechskantschraube M7x50	Hexagon bolt M7x50	2
28	DIN 934/440	Sechskantmutter M7	Hexagon nut M7	2
29	520-14.614	Kettenspanner rechts	Chain tensioner right	1
30	520-15.653	Ankerlasche	Strip	1
32	DIN 125/550	Scheibe A 8,4	Washer A 8,4	1
33	520-15.150	Federbügel	Spring clip	1
34	DIN 933/590	Sechskantschraube M8x22	Hexagon bolt M8x22	1
35	561-17.111	Sicherungsmutter M8	Locking nut M8	1
36	520-15.206	Steckachse Ø 15	Knock-out spindle Ø 15	1
38	520-18.673	Kette mit Schloß 1/2"x5/16"-118 Glieder	Chain with lock 1/2"x5/16"-118 links	1

Einige Abbildungen sind mit den  
Teile nicht identisch

Some illustrations are not  
identical with the parts

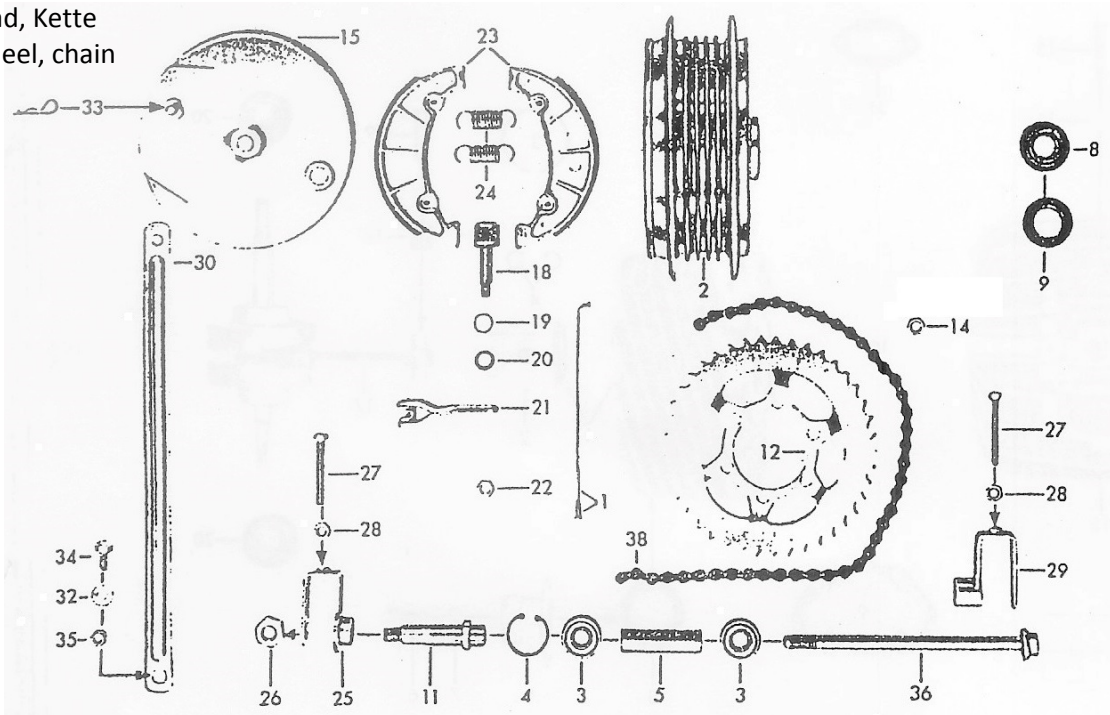

Bild Ill.	Bestel-Nr. Order No.	Benennung	Description	Stck. Pcs.
1-8	517-16.743	Scheinwerfereinsatz 6V; 35/35W ohne Glühlampe	Headlamp insert 6V; 35/35W without bulb	1
1	517-16.927	Glashaltering	Lens retaining ring	1
2	519-16.901	Verschlussschraube	Locking screw	1
3	517-16.933	Sprengdraht (Stück)	Spring (piece)	6
4	517-16.928	Dichtring	Gasket	1
5	517-16.929	Streuscheibe	Glass	1
6	517-16.930	Refektor	Reflector	1
7	517-16.931	Zugfeder	Draw spring	1
8	517-16.932	Lampenfassung	Lamp holder	1
9	DIN 72601/250	Glühlampe weiss 6V; 35/35W	Bulb white 6V; 35/35W	1
10	517-16.742	* Scheinwerfergehäuse	* Headlamp casing	1
11	520-16.914	Kabeltülle	Cable sleeve	1
12	520-16.915	Kabeltülle	Cable sleeve	1
13	520-16.604	* Scheinwerferhalter links	* Headlamp holder left	1
14	520-16.605	* Scheinwerferhalter rechts	* Headlamp holder right	1
15	520-16.655	* Klemme	* Clamping	4
16	DIN 933/346	Sechskantschraube M6x16	Hexagon bolt M6x16	4
17	DIN 933/570	Sechskantschraube M8x18	Hexagon bolt M8x18	2
--	DIN 9021/700	Scheibe A 8,4	Washer A 8,4	2
--	DIN 125/400	Scheibe A 6,4	Washer A 6,4	4
18	520-16.701	Schlußleuchte ohne Glühlampe	Rearlight without bulb	1
19	520-16.900	Lichtaustritt	Light outlet	1
20	DIN 72601/	Glühlampe 6V; 21-5W	Bulb 6V; 21-5W	1

\* unbedingt Farbe angeben \* state colour

Elektrische ausrüstung  
Electrical equipment  
2/3

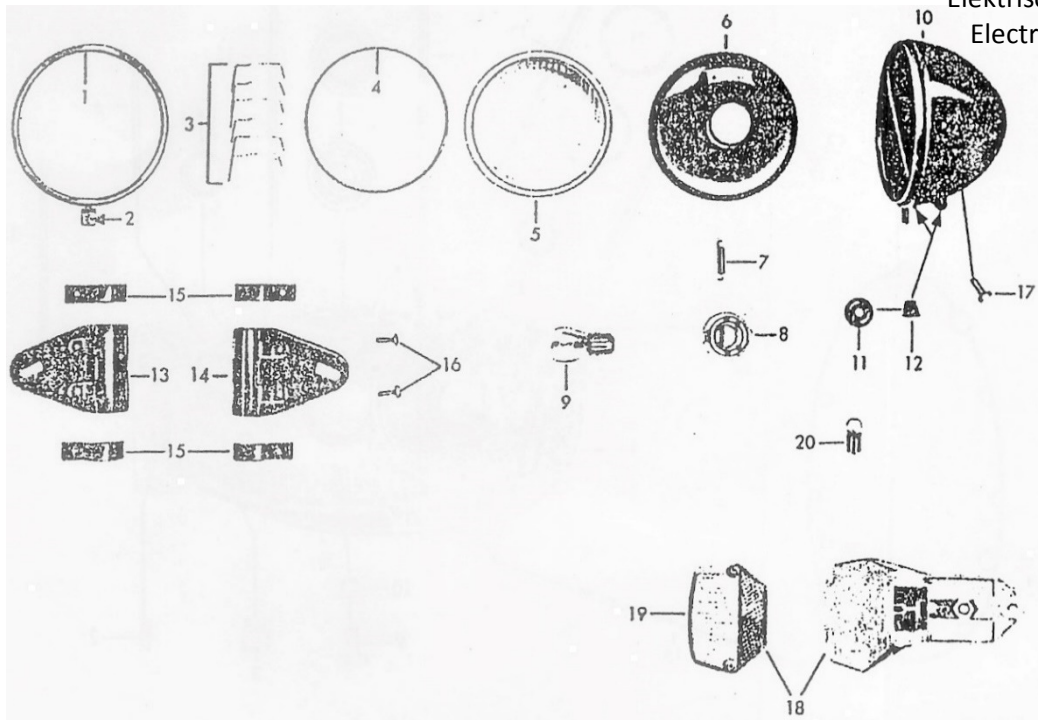

Bild Ill.	Bestel-Nr. Order No.	Benennung	Description	Stck. Pcs.
1	6060 z 107	Batterie 6V, 8 Ah	Battery 6V; 8 Ah	1
2	520-16.665	Batteriehalter	Battery holder	1
3	520-16.117	Gummiplatte 40x140x4	Rubber plate 10x140x4	1
4	514-10.118	Gummi 30 mm lang	Rubber 30 mm long	3
5	520-16.610	Gummiband	Rubber band	1
6	304-07.260	Steckhülsegehäuse	Plug housing	1
7	304-07.249	Steckhülse 7,4x0,3 dick	Plug sleeve 7,4x0,3 thick	5
8	304-07.276	Isolierhülse	Plug sleeve	6
9	520-16.255	Rundstecker	Round plug	2
10	6160 z 237	Leitungsverbinder	Cable coupler	1
11	DIN 72581/500	Sicherung A 8	Fuse	2
12	DIN 46247/400	Steckhülse 6,3x1	Plug sleeve 6,3x1	10
13	517-16.935	Lichtschalter	Light switch	1
14	520-16.741	Blinkerschalter	Flasher switch	1
15	500-16.703	Blickerleuchte ohne Lampe	Flasher lamp without bulb	2



Bild Ill.	Bestel-Nr. Order No.	Benennung	Description	Stck. Pcs.
16	500-16.901	Lichtscheibe	Glass lens	2
--	500-16.902	Schraube M14x0,75	Screw M14x0,75	2
--	DIN 85/475 A	Linsenschraube M6x10	Oval-head screw M6x10	4
17	DIN 72601/575	Glühlampe 6V/18W	Bulb 6V/18W	2
18	432-10.210	Gummitülle	Rubber sleeve	1
19	521-16.604	Blinkgeber 1x18W; 6V	Flasher unit 1x18W; 6V	1
--	521-16.140	Schutzhülse für Blinkgeber	Cap for flasher unit	1
20	520-16.257	Schutzkappe	Protecting cap	2
21	520-16.725	Stopplightschalter	Stop light switch	1
22	520-16.901	Schutzkappe	Protecting cap	1
23	518-16.130	Gleichrichter	Rectifier	1
24	519-16.724	Tachometer Ø60, M18x1,5	Speedometer Ø60, M18x1,5	1
25	520-16.607	Tachospirale 885 mm lang	Speedometer flexible shaft	1
26	520-16.765	Horn 6V, 335 Hz	Horn 6V, 335 Hz	1
--	520-16.404	Schutzkappe für Horn	Protecting cap for horn	2
27	686-16.129	Kupplungsstück	Connecting piece	1

Lenker, Armaturen, Seilzüge  
 Handlebar, armatures, cables  
 1/2

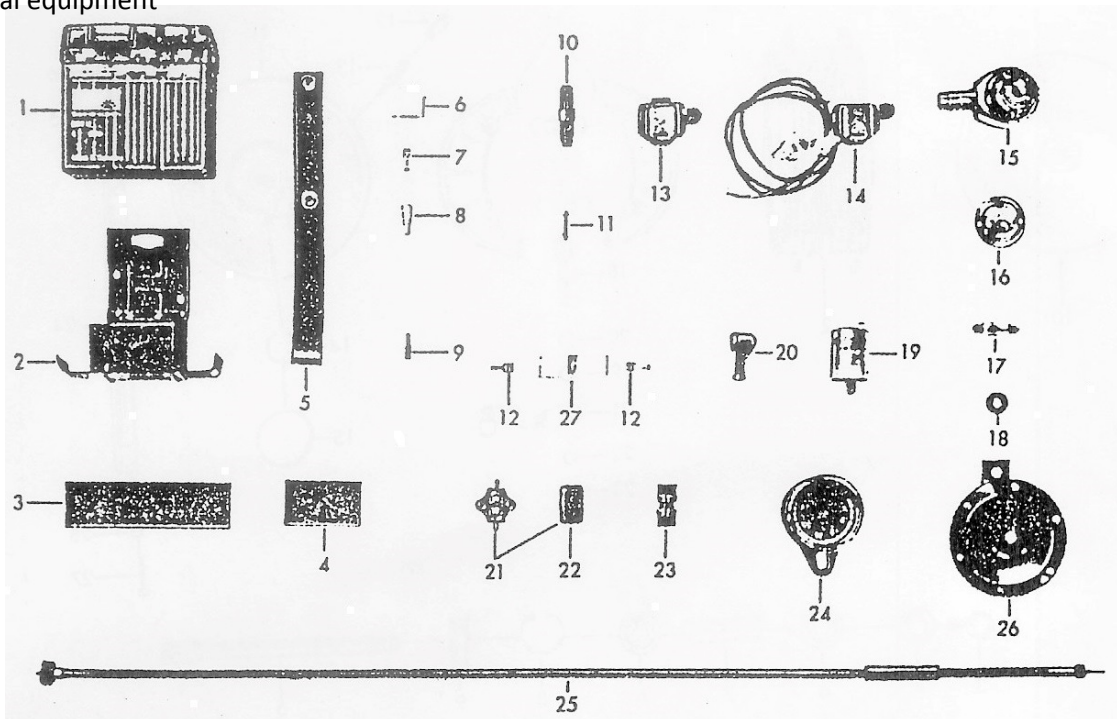

Bild Ill.	Bestel-Nr. Order No.	Benennung	Description	Stck. Pcs.
1	520-13.604	Lenker	Handlebar	1
2	520-13.131	Halter oben	Mounting bracket top	2
3	520-13.132	Halter unten	Mounting bracket bottom	2
4	DIN 931/640	Sechskantschraube M8x75	Hexagon bolt M8x75	4
5	DIN 931/580	Sechskantschraube M8x50	Hexagon bolt M8x50	2
-	DIN 125/550	Scheibe A 8,4	Washer A 8,4	4
6	561-17.111	Sicherungsmutter M8	Locking nut M8	2
7	510-17.727	Bremshebel kpl. rechts	Brake lever cpl. right	1
8	510-17.726	Kupplungshebel kpl. links	Clutch lever cpl. left	1
9	520-17.909	Gelenkstück	Joint	1
10	520-17.910	Bremshebel allein	Brake lever single	1
11	520-17.911	Kupplungshebel allein	Clutch lever single	1
12	520-17.912	Hebelschraube	Lever screw	2
13	520-17.913	Sicherungsmutter M6	Locking nut M6	2
14	520-17.914	Deckel	Cover	2
16	520-17.916	Verstellschraube	Adjuster screw	2
17	519-17.906	Faltenbalg	Bellow	2
18	520-17.917	Schutzkappe	Protecting cap	2
19	520-17.918	Lötnippel-Aufnahme	Support for soldered nipple	2
20	520-17.718	Gasdrehgriff kpl.	Throttle twist grip cpl.	1

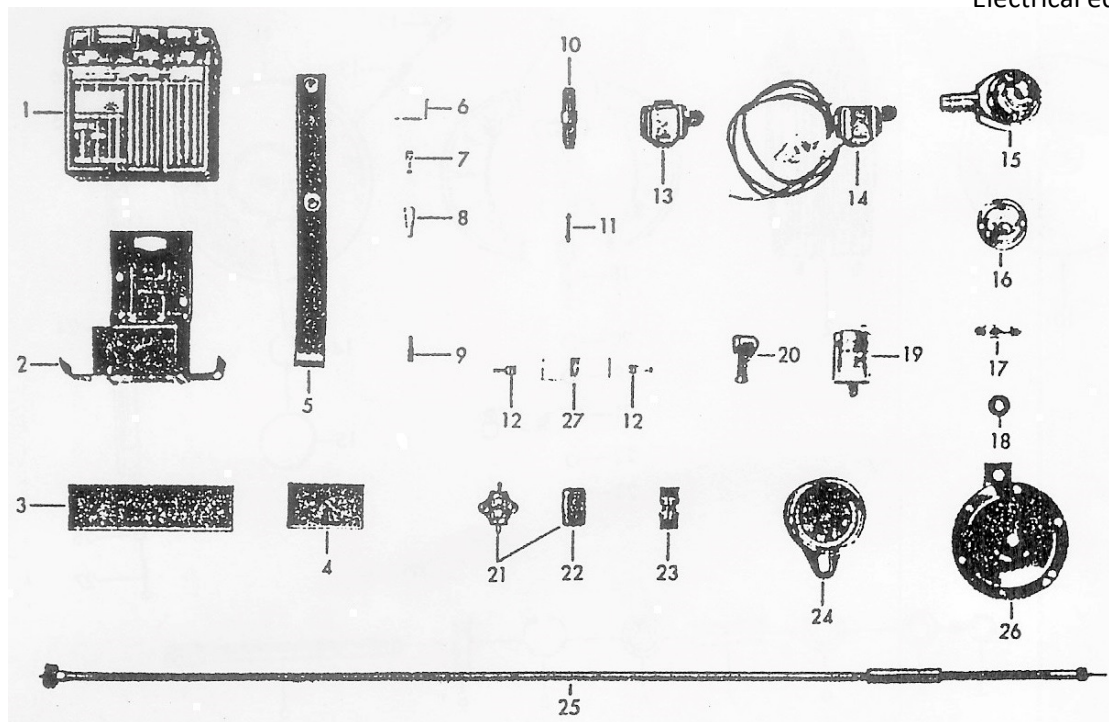
Lenker, Armaturen, Seilzüge  
 Handlebar, armatures, cables  
 2/2

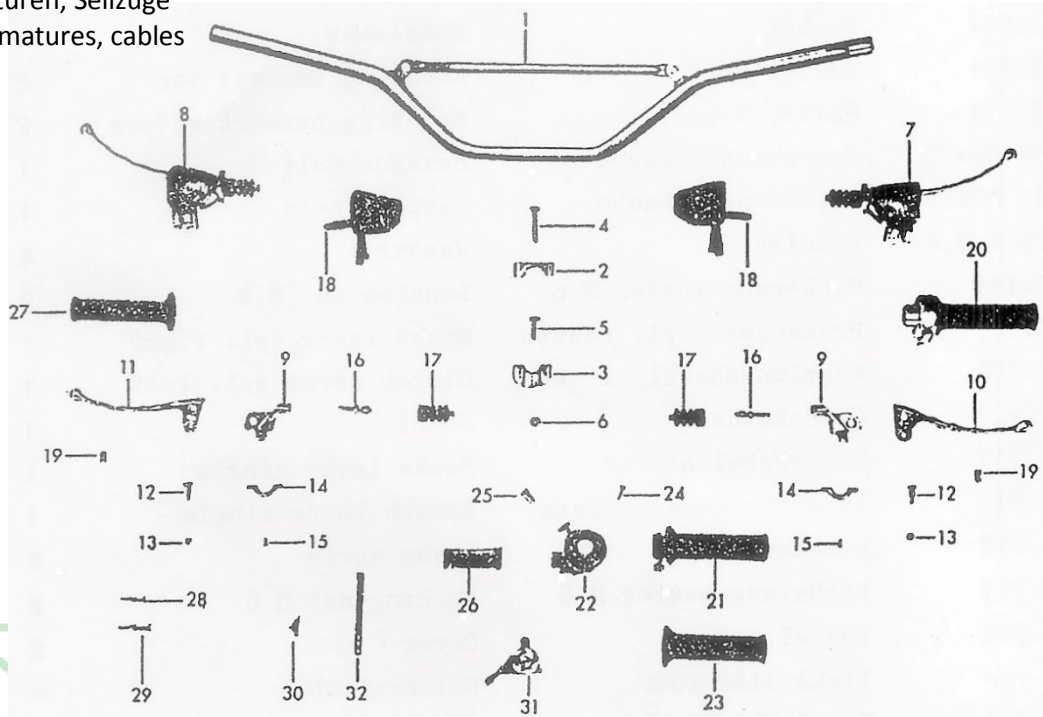

Bild Ill.	Bestel-Nr. Order No.	Benennung	Description	Stck. Pcs.	
	21	520-17.919	Griffrohr kpl.	Grip tube cpl.	1
	22	520-17.921	Gehäuse kpl.	Housing cpl.	1
	23	520-17.920	Drehgriffüberzug	Grip cover	1
	24	400-17.912	Linsenschraube	Oval-head screw	1
	25	520-17.922	Rändelschraube	Knerled screw with compression spring	1
	26	520-17.923	Schutzkappe	Protecting cap	1
	27	516-17.705	Festgriff links	Fixed grip left	1
--		520-17.620	Bremszug A 1,6x1245	Bowden cable for brake A 1,6x1245	1
	28	428-17.715	Verstellschraube	Adjuster screw	1
--		520-17.621	Kupplungszug A 1,6x1115	Bowden cable for clutch A 1,6x1115	1
	29	515-17.715	Verstellschraube	Adjuster screw	1
--		520-17.634	Gaszug A 1,6x1106	Bowden cable for throttle A 1,6x1106	1
	30	428-17.635	Plastiköler	Plastic oiler	4
--		520-17.627	Starterzug A 1,6x990	Startercable A 1,6x990	1
	31	520-17.717	Regulierhebel kpl.	Starter lever cpl.	1
	32	685-36.187	Halteklammer	Retaining clip	4

Schutzbleche, Bügel  
Fairrings, strap



Bild Ill.	Bestel-Nr. Order No.	Benennung	Description	Stck. Pcs.
1	520-19.162	Vorderradschutzblech	Front wheel mud guard	1
2	520-19.635	Bügel oben	Mounting bracket, top	1
3	520-19.634	Bügel unten	Mounting bracket, bottom	1
4	517-19.124	Distanzstück	Distance piece	1
5	520-19.637	Hinterradschutzblech	Rear wheel mud guard	1
-	520-19.163	Abstützwinkel	Angle	1
-	M1806 z 59	Gummitülle	Rubber sleeve	2
6	520-19.608	Halter	Holder	1
-	600 z 5	Schwingmetallpuffer	Rubber-metal buffer	3
-	520-19.151	Kunststoffplatte 400 mm lang, 1 mm dick	Plastic plate 400 mm long, 1 mm thick	1
-	DIN 933/346	Sechskantschraube M6x16	Hexagon bolt M6x16	18
-	DIN 125/400	Scheibe A 6,4	Washer A 6,4	11
-	DIN 933/370	Sechskantschraube M6x25	Hexagon bolt M6x25	2
-	517-22.111	Sicherungsmutter M6	Locking nut M6	13
-	517-21.114	Gummischeibe 6,5x20x3,5 mm	Rubber washer 6,5x20x3,5 mm	17
-	1301 z 1019	Scheibe 6,2x22x1 mm	Washer 6,2x22x1 mm	3
-	DIN 934/400	Sechskantmutter M6	Hexagon nut M6	8

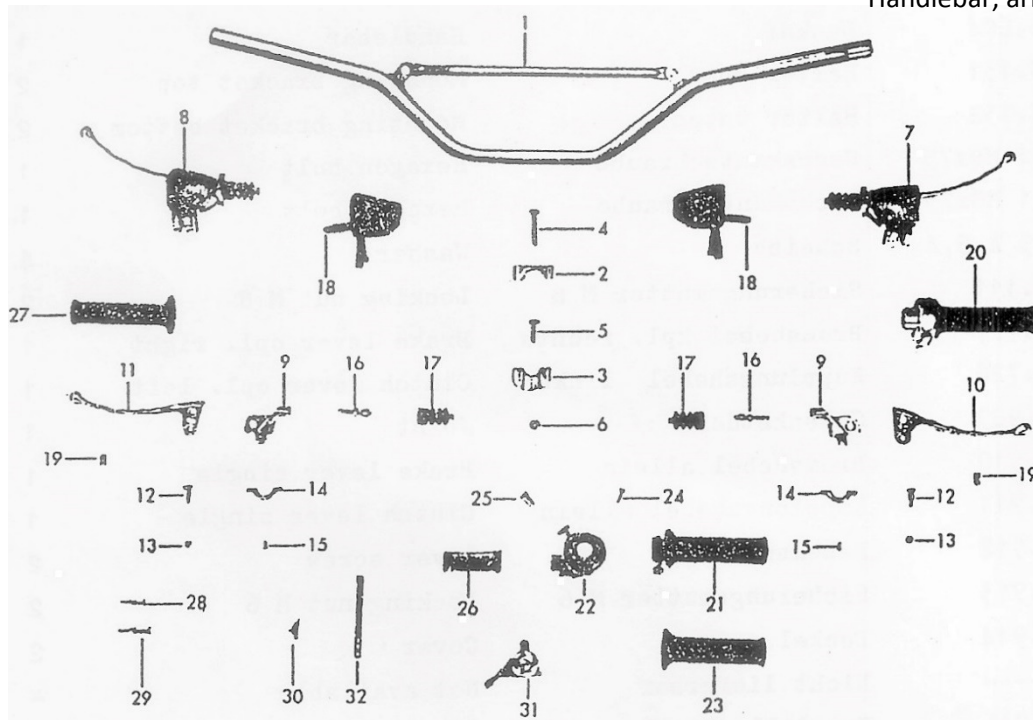

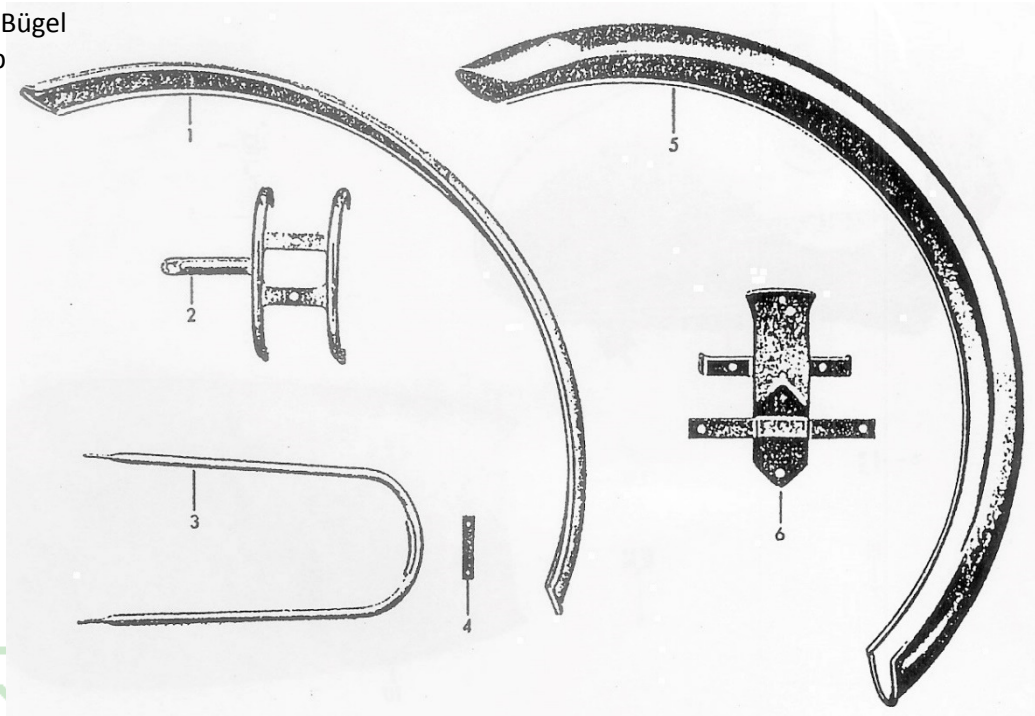
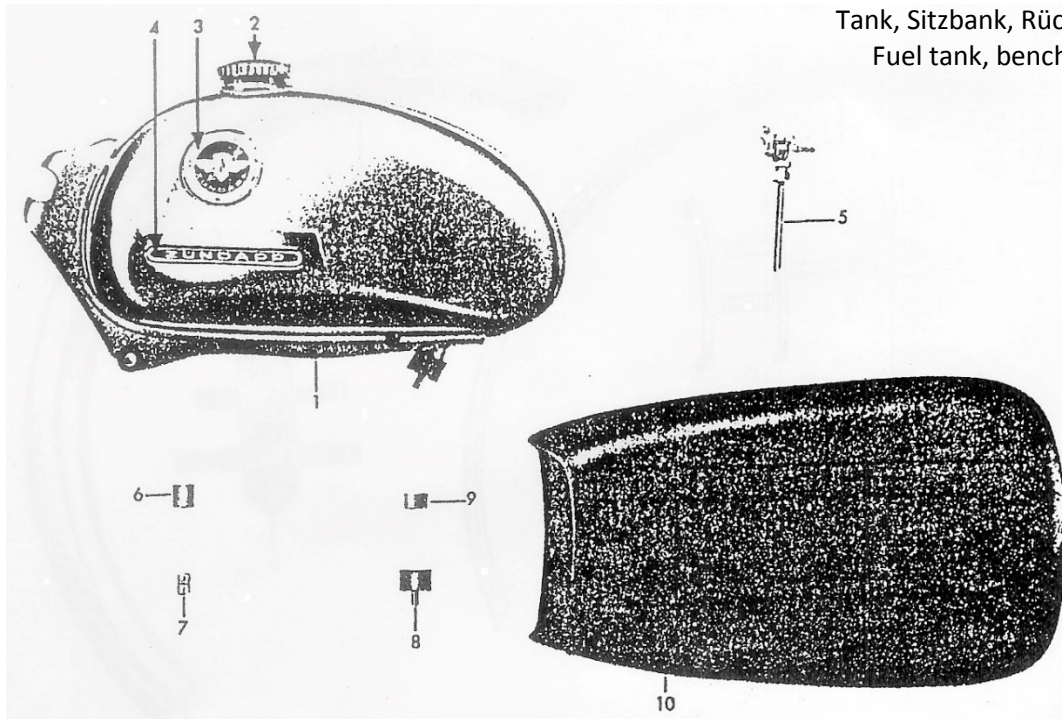

Tank, Sitzbank, Rückblickspiegel  
Fuel tank, bench seat, mirror

Bild Ill.	Bestel-Nr. Order No.	Benennung	Description	Stck. Pcs.
1	520-20.718	* Tank ohne Benzinhahn	* Fuel tank without fuel tap	1
2	432-20.610	Tankverschluß	Tank cap	1
3	440-20.100	Plakette	Plaque	2
4	520-20.176	Plakette	Plaque	2
5	434-20.703	Benzinhahn kpl.	Fuel cap cpl.	1
-	DIN 73379/	Benzinschlauch	Fuel tube	
		Coroplast A5x9x290	Plastic A5x9x290	1
6	520-20.145	Büchse 11,5x20x22	Bush 11,5x20x22	2
7	520-20.167	Büchse 8,2 mm Innan Ø	Bush Ø 8,2 mm	2
-	DIN 931/	Sechskantschraube M8x35	Hexagon bolt M8x35	2
8	520-10.288	Schwingmetallpuffer	Swing suspension buffer	1
9	520-20.179	Büchse 8,6x22x15	Bush 8,6x22x15	1
-	DIN 551/	Gewindestift	Pin	1
-	520-20.705	Werkzeugsatz	Tool kit	1
-	520-20.619	Steckschüssel SW 22	Boc spanner SW 22	1
10	520-21.623	Sitzbank	Bench seat	1
--	512-21.701	Rückblickspiegel	Mirror cpl.	1
--	512-21.100	Klemmstück	Clamping piece	1

\* unbedingt Farbe angeben \* state colour

Ausbesserungslack  
Tin repair varnish

Bild Ill.	Bestel-Nr. Order No.	Benennung	Description	Stck. Pcs.
-	005-02.060	1/8-Kilo-Dose Ausbesserungslack 1/8 kilo tin repair varnish	= racing-rot = racing red	
-	005-02.038	1/8-Kilo-Dose Ausbesserungslack 1/8 kilo tin repair varnish	= renn-silber für Schutzbleche = racing-silver for farings	



ZÜNDAPP GS 125



